

ACTUATOR SERIES 90 PROPORTIONAL

ESBE actuator Series 90 for operating ESBE mixing valves DN 15–150. This series is provided with adjustable cam discs to obtain adjustable operating range which make the series very flexible.



Proportional

OPERATION

The ESBE series 90 actuator is a compact actuator for operating rotary mixing valves. The actuator is reversible and is provided with limit switches which are actuated by cam discs. For 12550100 and 12550200 the operating range is 90° resp. 180°, and for 12550400 the operating range is 355°. The actuator is provided with a disconnection for manual operation and has an indication on the front showing valve position.

Supply voltage 24 V AC/DC. The actuators are factory set at 0–10 V and 60 s for 12550100 resp. 120 s for 12550200 and 12550400. Any adjustments are made by removal of front cover.



1 To operate the valve manually, push the button and use the lever. The electric current is automatically disconnected as long as the button is in the lower position.

2 Turn the valve to the desired position.



3 To return to automatic operation, bring the lever to the position where it locks, and the button returns to the upper position. The current supply is now connected.

SUITABLE MIXING VALVES

- Series VRG100*
- Series MG
- Series VRG200*
- Series G
- Series VRG300*
- Series F
- Series VRH100*
- Series BIV
- Series VRB100*
- Series T, TM
- Series VBF100, DN20-65*
- Series H and HG

*Separate adaptor kit is required, see below

ADAPTOR KITS

Required adaptor kits for easily fitting onto an ESBE rotary mixing valve is available in three different styles. Adaptor kit designed for ESBE mixing valve series MG, G, F, BIV, H, HG is supplied with each actuator. Adaptor kits for ESBE mixing valve series VRG, VRH, VRB and VBF can be ordered separately.

Art. No.

16051300 (= supplied with actuator)

_____ ESBE valve series MG, G, F, BIV, T, TM, H, HG

16053300 _____ ESBE valve series VRG, VRH, VRB

13905100 _____ ESBE valve series VBF100

Adaptor kits for other mixing valves and valves built-into boilers are available as follows:

Art. No.

16053600 _____ BRV, Meibes, Oventrop, Watts

16053900 _____ Honeywell Centra ZR, DR, DRG, DRU (DN15–50)

16051700 _____ Honeywell Centra Kompakt DRK/ZRK

16051300 _____ Sauter MH32...H42...

16052600 _____ Schneider Electric/TAC-TRV

16052500 _____ Siemens VBG31, VBI31, VBF21, VCI31

16051400 _____ TA-VTR, TA-STM

16051500 _____ Viessmann (DN20–25)

TECHNICAL DATA

Ambient temperature: _____ max. +55°C

_____ min. -15°C

Power supply: _____ 24 ± 10% V AC/DC, 50/60 Hz

Power consumption: _____ 5 VA

Enclosure rating: _____ IP 54

Protection class: _____ II

Torque: _____ See table

Weight: _____ 0,8 kg

CE LVD 2014/35/EU
EMC 2014/30/EU
RoHS 2011/65/EU

ACTUATOR SERIES 90 PROPORTIONAL

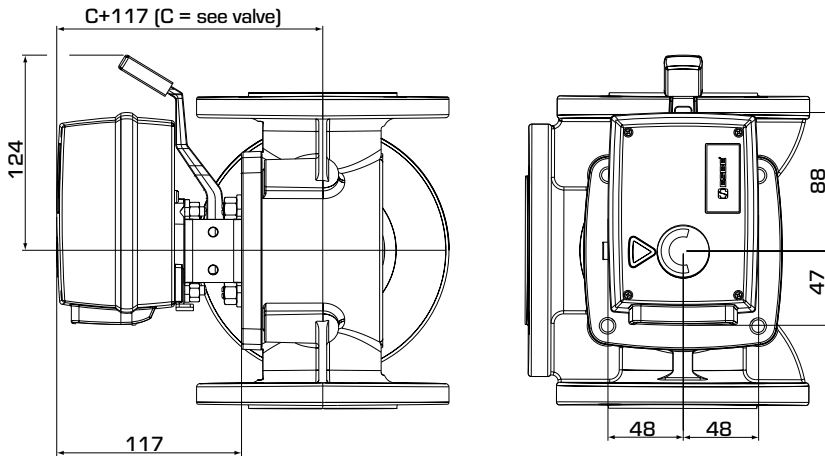

Installation dimensions for Actuator Series 90 with ESBE series MG, G, F, T/TM, H/HG and BIV mixing valves

SERIES 90, PROPORTIONAL 24 V AC/DC

Art. No.	Reference	Voltage [V]	Running time [s]	Torque [Nm]	Control signal	Remark
12550100	92P	24	60/90/120 ¹⁾	15	0-10 V, 2-10 V, 0-20 mA, 4-20 mA	Operating range 30-90°
12550200	92P2		120/180/240 ²⁾	15		Operating range 30-180°
12550400	92P4		130/260/390 ³⁾	15		Operating range 180-355°

Note 1) At 90° operating range. 2) At 180° operating range. 3) At 355° operating range.

WIRING

The actuator should be preceded by a multi-pole contact breaker in the fixed installation.

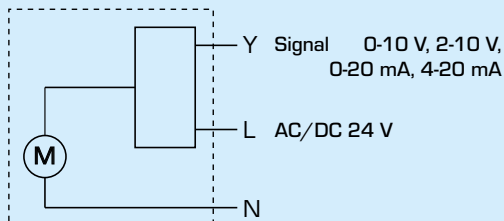

Actuator, Art. No.
12550100, 12550200
12550400