

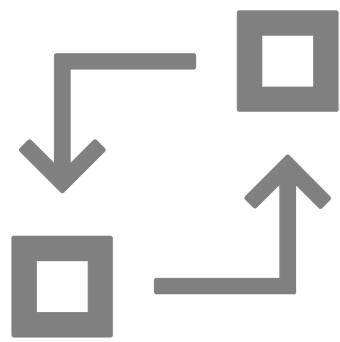

essco ENERGY



EDGE HEATING AND COOLING INTERFACE UNITS



Heat networks

There are currently over 500,000 properties, connected to a district or communal heating network in the UK, and this figure is set to grow rapidly with the government targeting 20-40% of heat from heat networks by 2040 from the current 2%, in a bid to reduce carbon emissions.

To capitalise on the benefits that heat networks offer, it is vital that systems are designed and delivered with efficiency and performance in mind.



Advances in HIU technology and smart methods of control mean modern heat network developments can operate at optimum efficiency with minimal energy waste, at a lower cost and with simple ongoing management. Essco's EDGE range offers all this and more.



Highlights

EDGE units feature first-class components, including the market-leading flow control valve from ESBE and electronic temperature control technology.



Powered by
ESBE



STANDARD FEATURES

DESIGN

- **Ultra-Compact** unit dimensions
- **Outputs** available to suit most applications
- **Easy access** to components for installation and maintenance
- **Optional jig** for all top or all bottom connection entry

EFFICIENCY

- **Weather compensation** for fast supply of heating and low running costs
- **Keep-warm** functionality for quick hot water response

REGULATIONS

- **KIWA Regulation 4** Approved unit and components
- **Tested to BESA** HIU standard with 29°C VWART (EDGE-TM model)

METERING AND BILLING

- **Billing ready** for any standard Credit or PAYG system
- **MID approved**, Class 2 Ultrasonic M-Bus meter
- **Open access** to meter readings via standard M-Bus set-up

CONTROL

- **Intelligent electronic** PID control
- **Modulation** of primary flow rate using ESBE SLB control valves

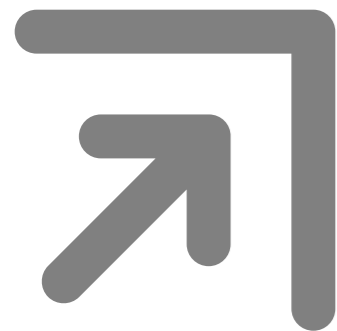

EDGE range

There is an EDGE heat interface unit to suit most communal or district heating applications. You can find an overview of the models in the range below.

MODEL	EDGE-T	EDGE-C	EDGE-D	EDGE-S
	Twin plate HIU (P.6)	Single plate HIU (P.7)	Single plate HIU (P.8)	Single plate HIU (P.9)
Domestic Hot Water (DHW)	Instantaneous	Cylinder Feed	Instantaneous	-
	Indirect	Direct	Indirect	-
Space Heating (HTG)	Indirect	Indirect	Direct	Indirect

HEATING

Using PID control, heating demand is satisfied by modulating the primary flow rate using the ESBE SLB control valve, which determines the rate of heat transfer within the plate heat exchanger and ensures the set heating flow temperature is met through varying loads.

The required flow temperature is pre-settable and can be adjusted to suit the heating system. Additionally, the flow temperature can be adjusted automatically when utilising the weather compensation functionality, which can be configured with a heating curve to determine the flow temperature against outside temperature.

A Pulse Width Modulation (PWM) controlled variable speed Grundfos pump enables the EDGE HIU to vary the flow rate on the secondary heating system to maintain low return temperatures to the primary network for improved energy efficiency. The valve and pump are also used for on/off control of the heating, whereby both are turned off when there is no demand. The heating valve closes in less than 2 seconds and features zero leakage, thereby ensuring no unnecessary primary flow bypassing.

INSTANTANEOUS DOMESTIC HOT WATER (DHW)

Satisfying demand for hot water instantaneously, efficiently and consistently is vital to end-user comfort. EDGE HIUs are well equipped to deliver seamless DHW performance.



The temperature of the DHW is controlled by modulating the primary flow rate, which determines the rate of heat transfer within the plate heat exchanger. This ensures a consistent delivery of hot water through varying high and low flow conditions.

KEEP-WARM FUNCTIONALITY

The keep-warm facility ensures that the primary pipework to the HIU and the domestic hot water plate are kept warm to deliver a quick hot water response.

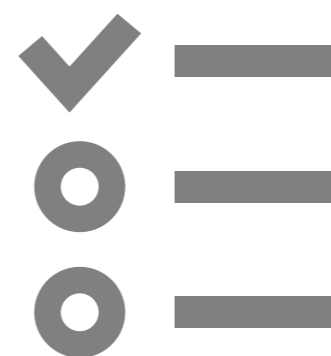

Technical details

	EDGE-T	EDGE-C	EDGE-S	EDGE-D
Primary Heating Circuit				
Maximum Flow Temperature			90°C	
Maximum Working Pressure			16 bar	
Maximum Differential Pressure Rating			4 bar	
Domestic Hot Water				
Operating Pressure	16 bar			16 bar
Space Heating				
Operating Pressure		3 bar		
Safety Relief Valve Rating		3 bar		
Expansion Vessel		8L		
Pump	Grundfos UPM3 PWM A-Rated pump			
General				
Plate Heat Exchanger (PHE)	SWEP PHE			
Control Valve(s) - Flow Rate/Energy Control	ESBE SLB control valve + actuator			
Dimensions	Height 666mm x Width 430mm x Depth 250mm			
Weight (Dry)	28kg		26kg	
Connections	¾" BSP Female Primary and Secondary connections, ½" PRV			
Pipework Insulation	9mm K-FLEX ST			
Plate Heat Exchanger Insulation	9mm expanded Polyethylene			
Case Material	Powder coated mild steel			
Metering and Billing				
Heat Meter	Ultrasonic, MID approved and class 2 accuracy (BS EN 1434) M-Bus meter			
Energy Shut-Off / Billing Valve	Included as standard			
Billing Valve Control in Power Failure	Power failure backup function as standard via battery			
Billing Ready (Credit & Prepayment)	Ready for connection to Minibems or another billing platform			
Regulations and Certification				
KIWA	KIWA Regulation 4 Approved unit			
CE	CE marked unit			
BESA (British Engineering Services Association) UK Standard for Heat Interface Units	Results published on BESA website - www.thebesa.com/ukhiu (Model Tested: EDGE T1 HIU with Minibems)			
Electrical				
Power Supply Voltage	220/240V 50Hz			
Power Consumption (Max / Standby)	<100W			
Warranty				
EDGE HIU Warranty	2-year parts and labour warranty			

EDGE-T

Twin plate heat interface units with indirect space heating and instantaneous domestic hot water.

Features

- Twin plate heat exchanger.
- Indirect space heating.
- Instantaneous domestic hot water.
- Most popular model in the range, designed for typical heat network systems.
- Equivalent to a combi boiler in terms of performance and functionality.
- Suited to homes with one to four beds.

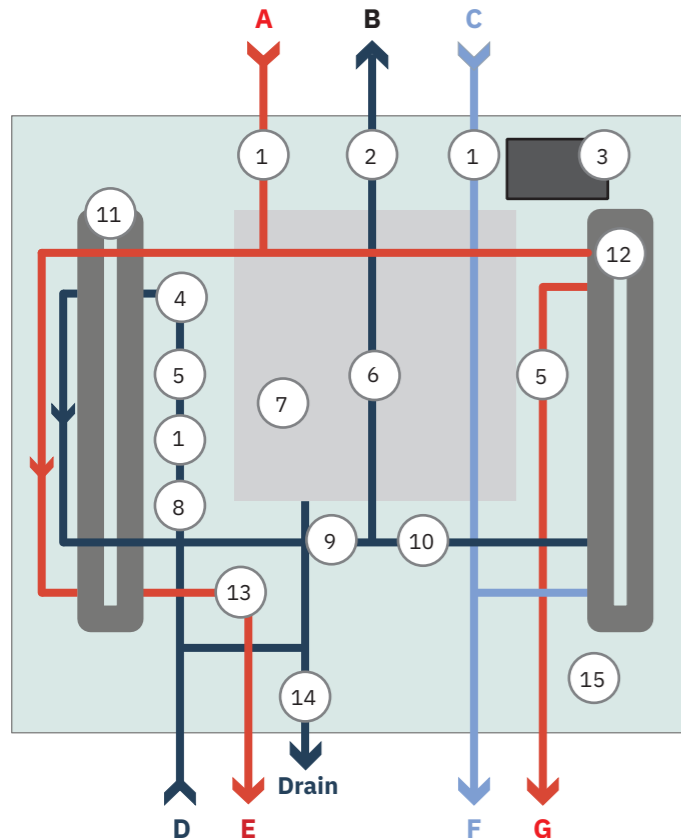
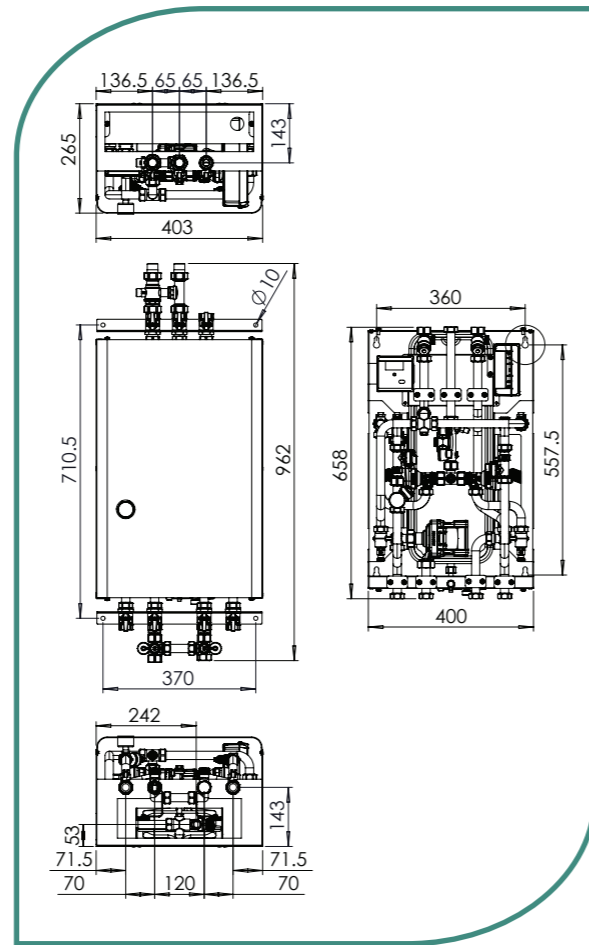

Key	Item
1	Strainers
2	Differential pressure control valve (Optional)
3	EDGE HIU controller
4	Grundfos pressure Sensor
5	Grundfos flow and temperature Sensor
6	Heat meter
7	Expansion vessel
8	Temperature gauge
9	ESBE SLB control valve for HTG
10	ESBE SLB control valve for DHW
11	Plate heat exchanger for HTG
12	Plate heat exchanger for DHW
13	Grundfos UPM3 PWM A-Rated pump
14	Safety valve
15	Filling loop
A	PRIMARY FLOW INLET
B	PRIMARY RETURN OUTLET
C	MAINS COLD WATER INLET
D	SECONDARY HEATING RETURN
E	SECONDARY HEATING FLOW
F	MAINS COLD WATER OUTLET
G	DHW SUPPLY

For typical heating and hot water performances see pages 12& 13.

EDGE-C

Single plate heat interface units with indirect space heating and direct cylinder feed for DHW

Features

- Single plate heat exchanger.
- Indirect space heating.
- Direct cylinder feed.
- Suited to applications where:
 - o stored hot water is more practical or desirable.
 - o a secondary return system is being used.

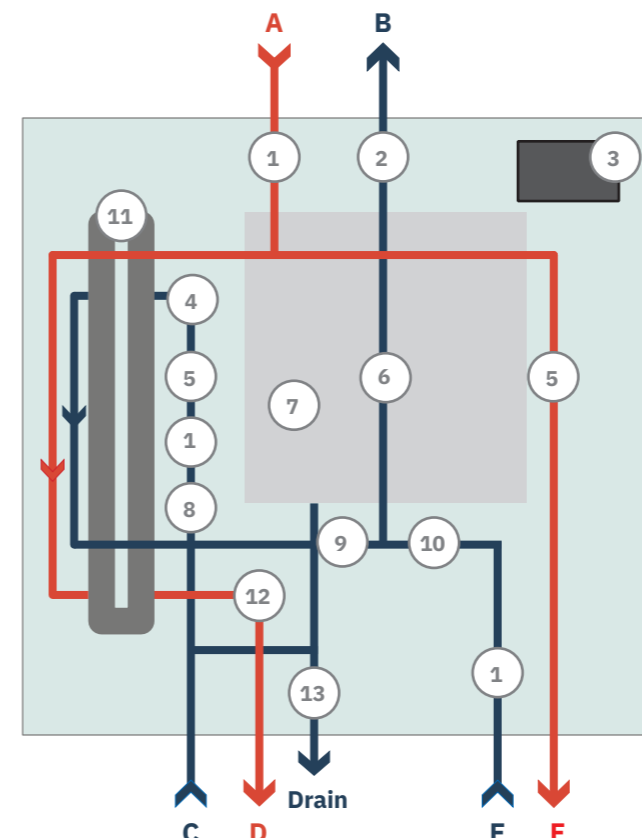
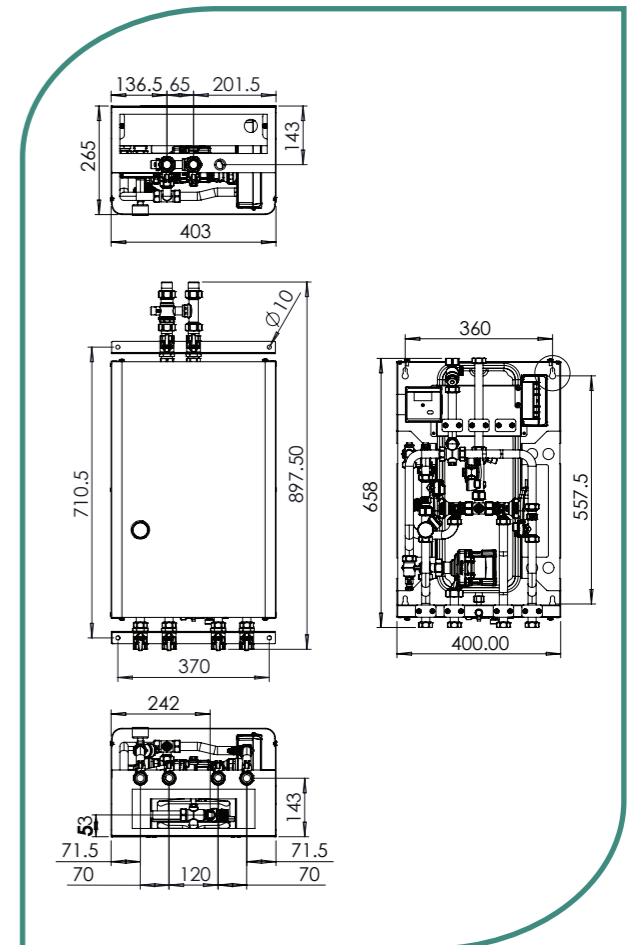

Key	Item
1	Strainers
2	Differential pressure control valve (Optional)
3	EDGE HIU controller
4	Grundfos pressure Sensor
5	Grundfos flow and temperature Sensor
6	Heat meter
7	Expansion vessel
8	Temperature gauge
9	ESBE SLB control valve for HTG
10	ESBE SLB control valve for DHW
11	Plate heat exchanger for HTG
12	Grundfos UPM3 PWM A-Rated pump
13	Safety valve
A	PRIMARY FLOW INLET
B	PRIMARY RETURN OUTLET
C	SECONDARY HEATING RETURN
D	SECONDARY HEATING FLOW
E	RETURN FROM CYLINDER
F	FLOW TO CYLINDER

For typical heating and hot water performances see pages 12& 13.

EDGE-D

Single plate heat interface units with indirect domestic hot water and direct space heating.

Features

- Single plate heat exchanger.
- Direct space heating.
- Instantaneous domestic hot water.
- Cost effective solution as no waste pipe is required from heating system Pressure Relief Valve (PRV).
- Suited to care homes and retirement properties where the risk of heating system damage is low.

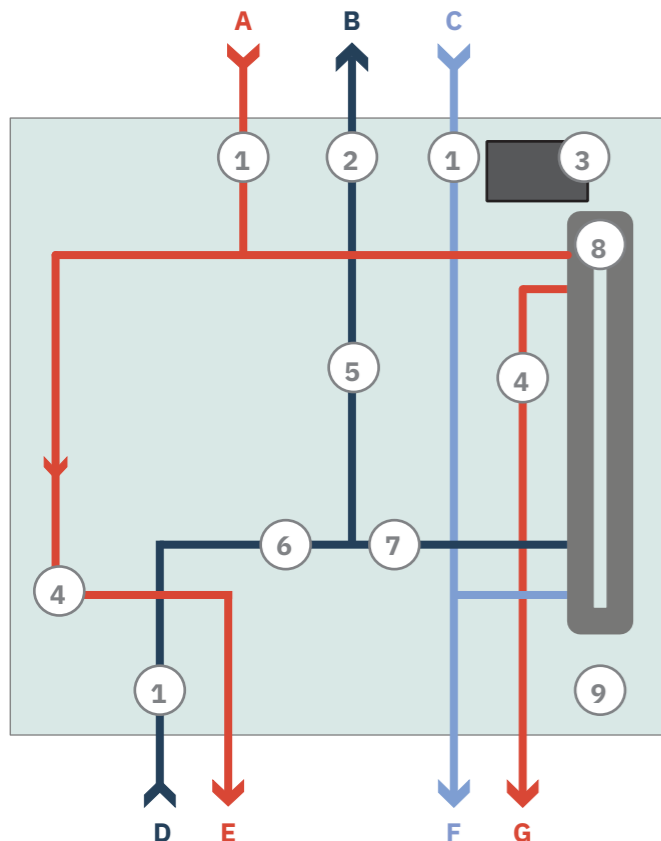
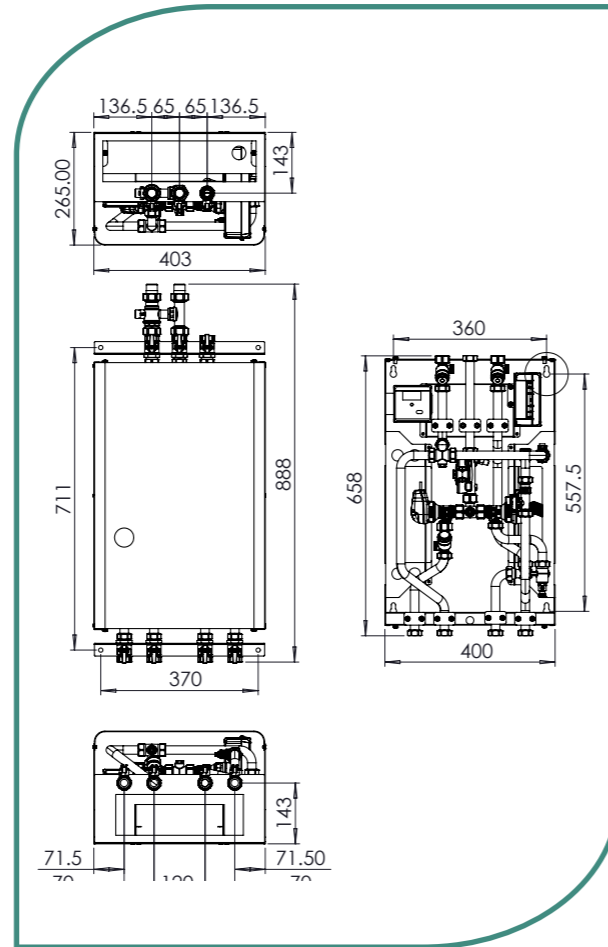

Key	Item
1	Strainers
2	Differential pressure control valve (Optional)
3	EDGE HIU controller
4	Grundfos flow and temperature Sensor
5	Heat meter
6	ESBE SLB control valve for HTG
7	ESBE SLB control valve for DHW
8	Plate heat exchanger for DHW
9	Filling loop
A	PRIMARY FLOW INLET
B	PRIMARY RETURN OUTLET
C	MAINS COLD WATER INLET
D	SECONDARY HEATING RETURN
E	SECONDARY HEATING FLOW
F	MAINS COLD WATER OUTLET
G	DHW SUPPLY

For typical heating and hot water performances see pages 12& 13.

EDGE-S

Single plate heat interface units with indirect space heating only.

Features

- Single plate heat exchanger.
- Indirect space heating.
- Typically suited to:
 - o Retrofit applications.
 - o Where an S or Y plan system is being used.

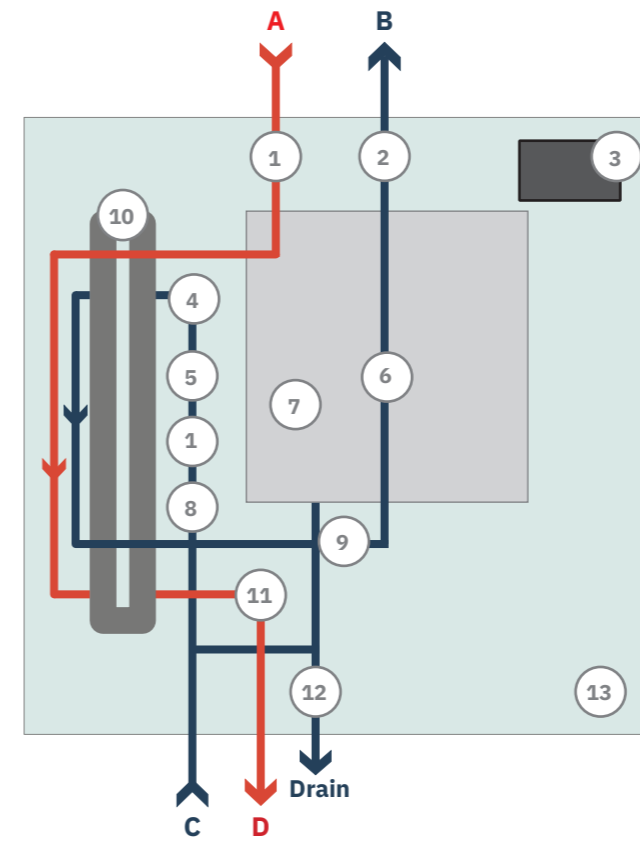
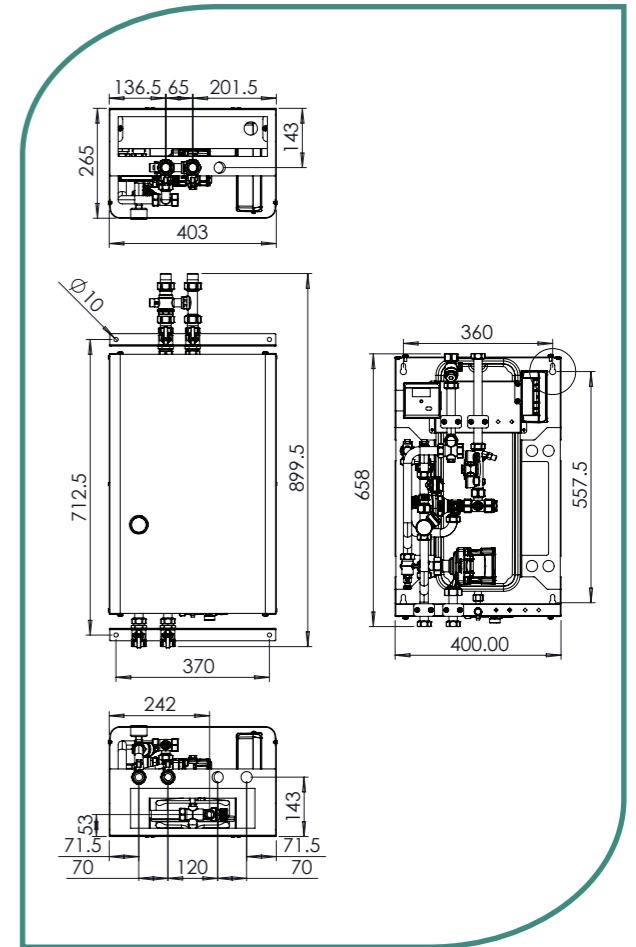

Key	Item
1	Strainers
2	Differential pressure control valve (Optional)
3	EDGE HIU controller
4	Grundfos pressure Sensor
5	Grundfos flow and temperature Sensor
6	Heat meter
7	Expansion vessel
8	Temperature gauge
9	ESBE SLB control valve for HTG
10	Plate heat exchanger for HTG
11	Grundfos UPM3 PWM A-Rated pump
12	Safety valve
13	Filling loop
A	PRIMARY FLOW INLET
B	PRIMARY RETURN OUTLET
C	SECONDARY HEATING RETURN
D	SECONDARY HEATING FLOW

For typical heating and hot water performances see pages 12& 13.



Typical Performances

Heating Performances

Heating performances for EDGE-T, EDGE-C and EDGE-S models below.

Primary Flow (°C)	Heating RADIATORS					
	HGT (°C)	Power (kW)	Primary return (°C)	Primary flow (l/s)	Min. diff. pressure primary (kPa)*	Secondary flow (l/s)
90	60/30 / 70/40	37 / 34	32 / 43	0.16 / 0.18	31.0 / 38.8	0.30 / 0.28
85	60/30 / 70/40	37 / 30	32 / 44	0.17 / 0.18	37.5 / 39.4	0.30 / 0.24
80	60/30 / 70/40	34 / 25	33 / 45	0.18 / 0.18	40.0 / 38.0	0.27 / 0.20
75	60/30 / 70/40	30 / 20	34 / 48	0.18 / 0.18	40.8 / 40.2	0.24 / 0.16
70	60/30	25	35.5	0.18	40.0	0.20
65	60/30	19	38.0	0.17	38.0	0.15
60	55/35	15	39.5	0.18	40.7	0.18
55	50/30	14	34.5	0.17	36.0	0.17

Primary Flow (°C)	Heating UNDER FLOOR HEATING					
	HGT (°C)	Power (kW)	Primary return (°C)	Primary flow (l/s)	Min. diff. pressure primary (kPa)*	Secondary flow (l/s)
90	45/35	12	35.01	0.05	4.0	0.29
85	45/35	12	35.01	0.06	5.0	0.29
80	45/35	12	35.02	0.065	6.0	0.29
75	45/35	12	35.04	0.074	7.5	0.29
70	45/35	12	35.07	0.084	9.7	0.29
65	45/35	12	35.14	0.098	13.1	0.29
60	45/35	12	35.30	0.12	19.0	0.29
55	45/35	12	35.70	0.15	30.0	0.29

*Data relates to the plate heat exchanger only, not the unit as a whole.



Typical Performances

Domestic hot water performances

Instantaneous domestic hot water performances for EDGE-T and EDGE-D models below.

Primary Flow (°C)	DHW (°C)	Power (kW)	DHW flow (l/m)	Primary return (°C)	Pressure loss primary (kPa)
90	10/55	90	29.0	14.0	33
85	10/55	90	29.0	15.0	39
80	10/55	80	25.7	16.0	37
75	10/55	75	24.0	17.0	40
70	10/55	65	21.0	15.5	38
65	10/55	55	17.6	21.0	37
60	10/55	45	14.4	25.0	40

EDGE-C domestic hot water performances are dependent on the Cylinder selected. (Not ESSCO supply)



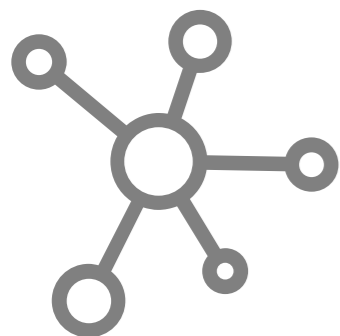

Minibems Connected Services (Optional)

Minibems is a software and service platform for the performance, operational and financial management of heat networks.

When the EDGE-TM model is selected, the Minibems connect operates as the brain of the unit to provide control and monitoring of all components, modulating heating and hot water delivery according to real-life demand.



Minibems Connect

REAL-TIME FLOW CONTROL

Using Dynamic real-time flow control, HIUs deliver a 60% average flow reduction whilst still providing the same level of heat and comfort to residents.

This results in maximum comfort for the end user, ultra-low primary network return temperatures and fuel and carbon savings of 25-40%*.

Dynamic provides tools for the identification and resolution of poor performing parts of a heat network and individual units are automatically monitored and parameters updated to improve performance.



NETWORK REQUIREMENTS

EDGE-TM HIUs connect to a Local Area Network (LAN), with smart functionality provided over the internet.

Units can also operate in 'Offline' mode where connection to a communication network is not possible. When in this mode units will operate with proportional valve control and delta T control of the heating circuit, but will not benefit from the additional Dynamic functionality.

Powered by mini bems

*Actual savings are dependent on project specific conditions.



Minibems Connected Services (Optional)

A complete digital management solution, allying excellent customer service with back-end enterprise IoT tools for day-to-day operation and reporting. Minibems transforms conventional heat network management into an optimised, data-driven & consolidated service from a single platform.

The building owner has the option to sign up for one, two or all three Minibems connected services.

Please refer to the EDGE-TM Minibems HIU Brochure for further information.



THE DIFFERENCE IS THE DATA

Minibems technology provides unparalleled access to data and allows for granular remote monitoring, diagnosis and management of heat networks, reducing the time and cost of unplanned maintenance.

Telematic is a 24/7/365 platform that uses data to empower specialist Minibems heating and hot water advisers to support customers and engineers and provide hassle-free heating.



FLEXIBLE AND COMPREHENSIVE METERING AND BILLING

Minipay is a credit and prepayment, metering and billing service for heat networks. Providing multiple payment methods, Minipay makes it easy for residents to make payments and keep their heating on, meaning customer satisfaction is high and ongoing management is hassle-free for building operators.

Minipay provides revenue assurance to network owners, with payment reconciliation and profit and loss accounting made easy.



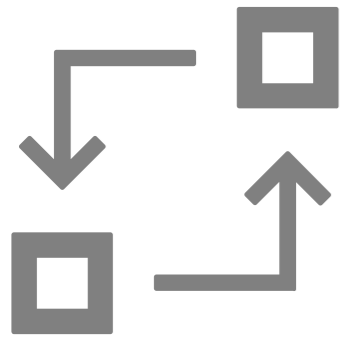

Open access to billing data

A key question for any heat interface unit supplier is – can I quickly and cheaply change metering and billing service provider if I want to?

Ultimately, the ability to change provider will future proof building operators against market changes and allow them to act in the best interests of residents. EDGE units offer the flexibility to change billing provider and can integrate easily with existing communication networks where required.

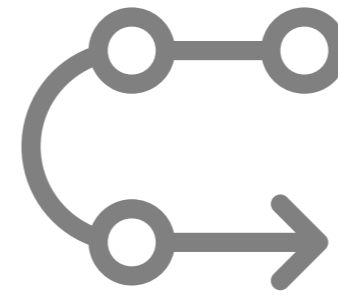
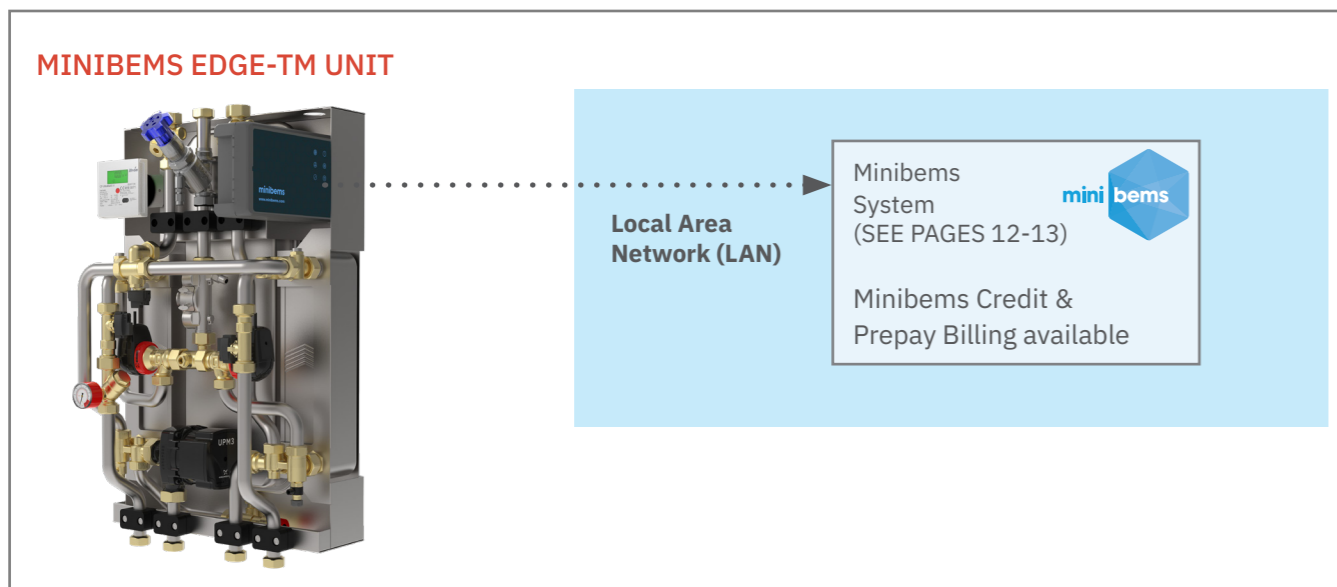
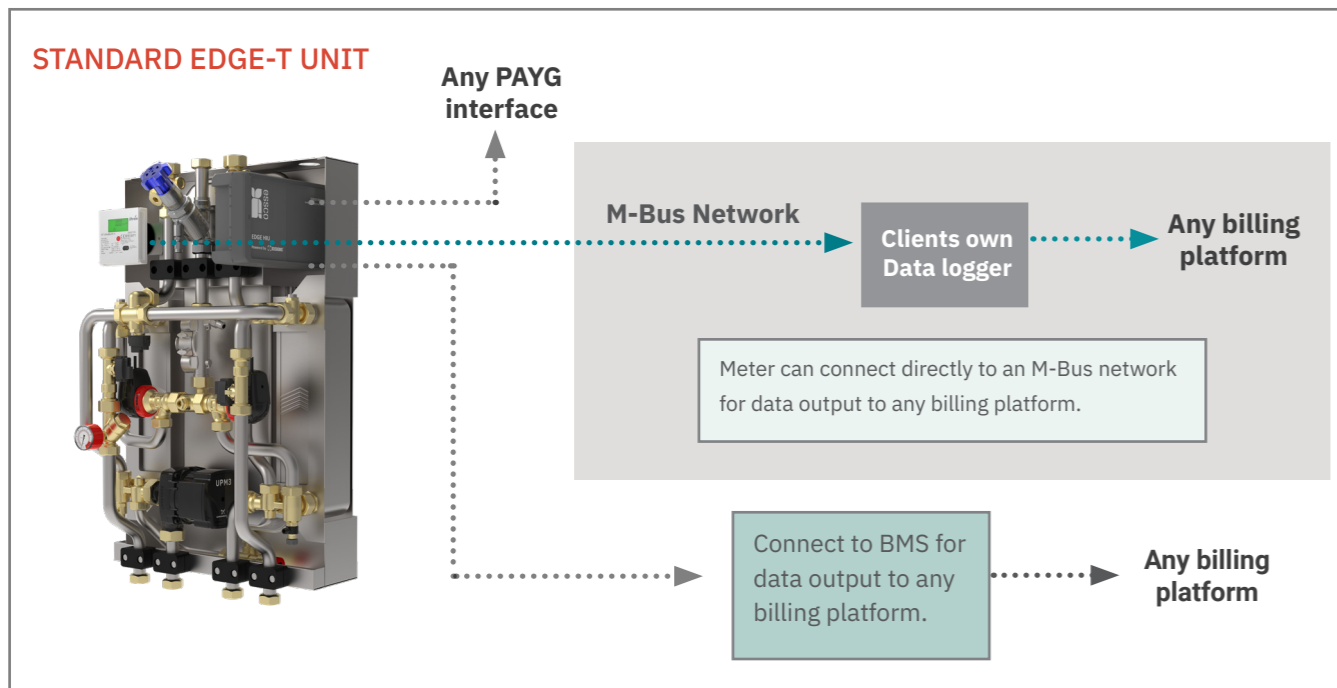

Ancillaries

ELYSATOR® Chemical-Free Water Treatment

Essco recommends the use of ELYSATOR® corrosion protection technology in heat network installations. The Elysator meets with Europe's most stringent water quality standards VDI-2035.

Completely chemical-free, the Elysator uses sacrificial magnesium anodes to extract oxygen, acid, and aggressive salts from the water and addresses both the symptoms and root cause of corrosion within recirculation heating and cooling systems. This reduces maintenance time and environmental impact.

We're so confident in the technology that we extend our EDGE HIU warranty to 5 years for new installations where an appropriate Elysator product is installed. That's 3 years on top of our standard 2-year warranty*



Water Meter Assembly (WMA)

The ESSCO WMA provides control and measurement of the cold-water supply to multi-dwelling buildings, such as apartments and office blocks connected to heat networks.

Supplied pre-insulated as standard, water meter assemblies feature an in-built pressure reducing valve, isolation valve, double check valve, pressure gauge and water meter carrier.

The WMA can be fitted with any approved water meter to match project the specification.



Thermostatic Radiator Valve

The unique MMA Evosense self-acting thermostatic radiator valve is designed to reduce commissioning time using state of the art balancing accuracy, which provides energy savings and low return temperatures to the heat network.



*Terms and conditions apply.



essco



Essco Group
Unit 5, Nelson Industrial Park
Herald Road
Southampton
SO30 2JH

T. 01489 779068
F. 01489 779069

www.esscogroup.co.uk