



H4 Pump Control Set Installation and Commissioning Manual

For underfloor heating with heat pumps and
low temperature systems.

Boxed and pre-assembled ready for installation, including:

- In-built 4-way deflector plate
- Temperature gauge measuring mixed water
- 'A' rated Stuart Turner 25/6 Pump
- 1" Male swivel joints for fast connection to 1" Female manifold tapings
- Nickel plated for improved appearance
- In-built non-return valve in flow elbow to enable simple system filling when commissioning
- 3/4" Female BSP flow and return connections
- Suitable for any manifold with connections on 210mm centres. (Also available in 200 and 225mm)
- Fully reversible offering with side or bottom entry primary connections

1. General

- 1.1** Provides control of flow and return water temperature in an underfloor heating system when using a heat pump or low temperature system. Pre-assembled and tested to ensure that it can be fitted with minimum on-site labour required and commissioned immediately once fitted.
- 1.2** Designed to connect to the right-hand side of a manifold with 200mm as standard (210 / 225mm optional) between the centres of the flow and return arms. The control group can also be altered to fit to the left-hand side of a manifold simply by turning the control group elbows through 180 degrees using the union fittings at the top and bottom of the pump. The pump motor may need to be rotated through 180 degrees to minimise the space occupied by the control group. Primary connections can be applied from the side or bottom of the control pack.

2. Connections & Dimensions

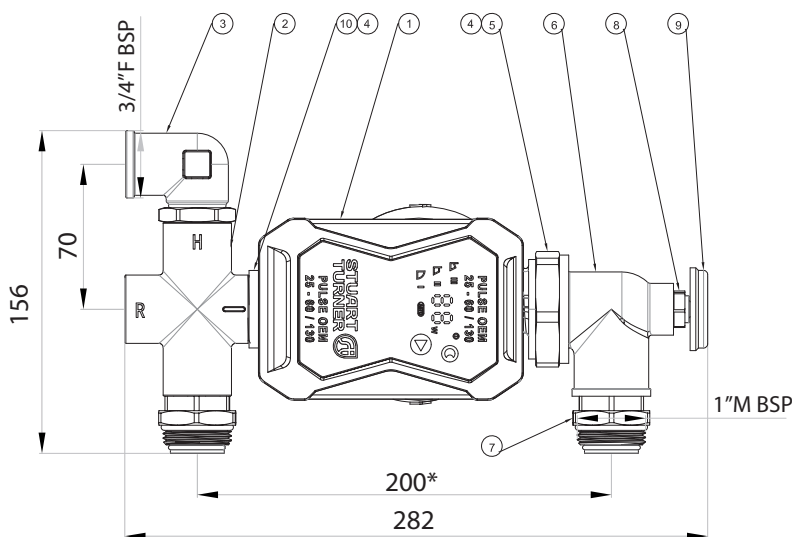

Item	Description	Qty
1	Stuart Turner 25/6 Pump	1
2	4-way Deflector Plate	1
3	Flow / Return Elbow	1
4	2mm Rubber Washer	2
5	1 1/2" Rapid Connection Nut	2
6	Elbow Flanged	1
7	1" Male BSP Flow and Return	2
8	3/8" Pocket	1
9	Temperature Gauge	1
10	Manifold Centre Distance Spacer	1
R	Return from Manifold / Flow to Heat Source	NA
H	Flow from Heat Source	NA

*STANDARD CENTRE DISTANCE. 210MM & 225MM ALSO AVAILABLE

3. Technical Data

Maximum static pressure	10 Bar
Maximum differential pressure	3 Bar
Maximum temperature	95°C
Inlet connections	2 x 3/4" BSPF
Outlet connections	2 x 1" BSPM swivel joint
Overall dimensions (mm)	290 h x 150 w x 140 h (Excluding item.3)
Material	Nickel plated brass
Power	20kW

4. Pre-Installation

Prior to installation, manifold configuration must be determined as left or right handed.

LB: LEFT HANDED
BOTTOM ENTRY*

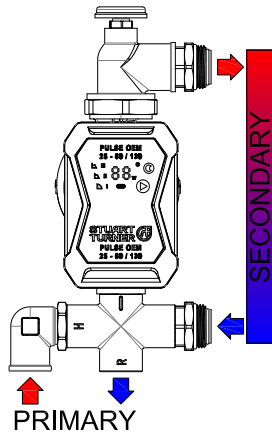

LS: LEFT HANDED
SIDE ENTRY

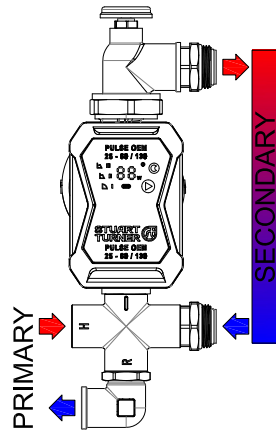

RB: RIGHT HANDED
BOTTOM ENTRY

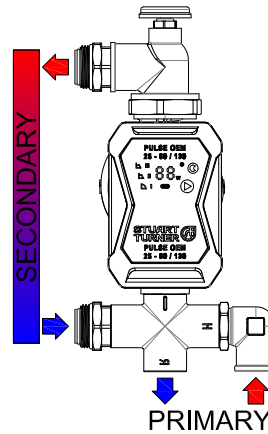

RS: RIGHT HANDED
SIDE ENTRY

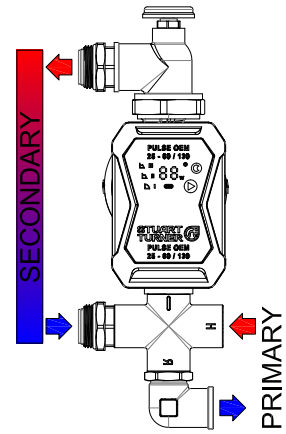

5. Installation

- 5.1** Carefully remove from the packaging and check that all components are in place and that nothing has been damaged during delivery.
- 5.2** The pump pack is supplied for connection to the right-hand side of the manifold but can be altered very simply for connection to the left-hand side. (See above)
- 5.3** To change orientation:
Loosen the pump rotating nuts (5) on the 4-way deflector plate (6) and rotate through 180 degrees. Re-tighten nut (5) after rotation.
- 5.4** Pipe connection orientation can be altered to suit using flow / return elbow (3) (supplied loose) fitted in either flow or return.
- 5.5** A swivel joint is fitted to each side of the control group for connecting to the 1" F manifold tapplings. Carefully offer up and screw the swivel joint threads evenly into the manifold using a 37mm A/F spanner: the use of a 31mm A/F spanner will also ensure that the connection to the pump mixer is kept tight. The joints use o-ring seals and care should be taken not to over-tighten them.
- 5.6** Once connected, finish securing the manifold and pump pack to the wall if not already completed.
- 5.7** The primary flow and return pipework can now be connected to the 2 x 3/4" F connections on the 4-way deflector plate. The flow connection is at the H and the return connection is at the R. It is recommended that ball valves are used to isolate this pipework where it is connected to the pump mixer.

6. Commissioning

6.1 Filling the UFH system - The in-built non-return valve in the flow elbow allows you to fill the circuits from the upper flow rail drain and fill valve only.

Be aware that you cannot get the benefit of this feature when filling via the primary flow and return connections or the lower manifold rail drain and fill valve.



6.2 The pump pack, manifold and underfloor circuits can now be filled and commissioned in accordance with the manifold instructions. Prior to filling, a final check of all joints should be made to ensure no connections have loosened during transit.

6.3 The pump is supplied with a pre-connected 1m long 3-core lead assembly ready for connection to the electrical control system. Ensure that the pump is filled and vented, operate the control system to call for heat then select the desired pump setting.

The H4 control pack comes pre-assembled ready for installation. Please ensure the pump connections are tightened before commissioning. These connections are equipped with EPDM seals.

7. Pump Settings



Buttons

All pump functions can be controlled with two buttons. The  button switches the night reduction function on and off. The  button controls the operating modes. The selected operating mode is shown in the clear field of the LED indicator.



Service Mode, setting the capacity range

The capacity range can be changed to 4m or 6m in service mode.

- Pump must be disconnected from the 230V mains voltage for at least 15 seconds
- Connect the pump to the 230V mains voltage
- Press the  and  buttons simultaneously with 3 seconds
- Release both buttons
- Select the capacity range with the  button
- - 4 = 4m
- - 6 = 6m
- Pump must be disconnected from the 230V mains voltage for at least 15 seconds
- Connect the pump to the 230V mains voltage

7. Pump Settings (Continued)

Technical data

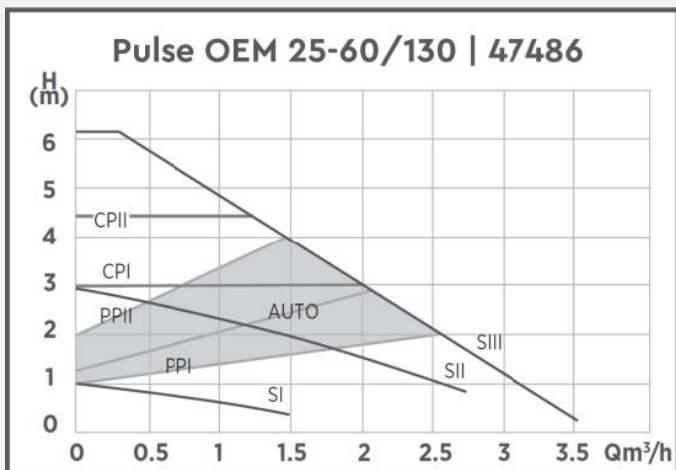

Control panel and LED display

1. Display of energy consumption in watts
2. Automatic night reduction display
3. Button for activating the automatic night reduction
4. Operating mode selection button
5. Display for activated AUTO Smartadapt mode
6. Display of the nine operating levels (characteristics) of the pump



Number of button presses	Display	Description	Symbol Display
0	AUTO (selected on supply)	AUTO Smartadapt	
1	PP1	Min. proportional pressure adjustment	
2	PP2	Average proportional pressure adjustment	
3	CP1	Min. constant pressure adjustment	
4	CP2	Average constant pressure adjustment	
5	I	Constant speed adjustment I	
6	II	Constant speed adjustment II	
7	III	Constant speed adjustment III	
8	AUTO	AUTO Smartadapt	

Malfunctions, causes and elimination

Maintenance work or repair attempts may only be performed by qualified personnel. Before conducting maintenance, cleaning and repair work, disconnect the system from the power supply and secure it against being switched on again by unauthorized persons. At high water temperatures and system pressures, wait for the pump to cool down beforehand. **There is risk of burns!**

Malfunction designation or pump error code	Possible cause	Remediation solution
The pump does not work, the display does not light up	Power error	Check the supply voltage at the pump. If necessary, switch the circuit breaker back on.
The pump works but delivers no water	Air in the system	Vent the pump (see chapter 8 in the manual).
	The valve is closed	Open the gate valve
Noise in the system	There is air in the system	Vent the system
	Pump capacity is too high	Check pump settings
The pump is making noise	Air in the pump	Vent the pump (see chapter 8 in the manual).
	System pressure is too low	Increase the pressure on the supply
	Defective expansion vessel	Check the amount of gas in the expansion vessel
The building does not heat up	Incorrect pump setting	Increase the setpoint (see chapter 7.3 in the manual)
	Night reduction can be switched on	Switch off night reduction
No automatic power adjustment in proportional pressure levels	An open overflow valve installed in the system makes it impossible to control	Remove or close the overflow valve, if possible.

Our other UFH products:



Single-loop Pump Pack

The single-loop assembly is designed to connect to new and existing heating systems with 15mm compression connections for the flow and return.

The temperature switch supplies power to the pump and will remain open until the existing heating system water is above 40°C. Following this, the switch will close activating the 'A' rated pump, which will allow the TMV to mix flow and return to the required UFH temperature. Unit is suitable for use with floor areas of 60–90sqm or max output of 5kW.



Thermostatic Pump Pack

The ESBE T4 pump pack is designed to control the UFH flow temperature between 20°C–55°C (BS1264 forced screed drying). Complete with ESBE 3.4kv 4-port thermostatic mixing valve, 'A' rated pump, built-in check valve and temperature gauge. Offering pipe centres of 210mm, 200mm and 225mm, fully reversible with side or bottom entry primary connections. This unit is suitable for use with floor areas up to 220sqm or a max output of 18kW.

