

Grundfos UPM3 Auto Pump

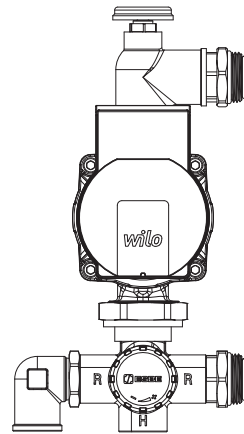

Wilo Para 25/6 SCU Pump

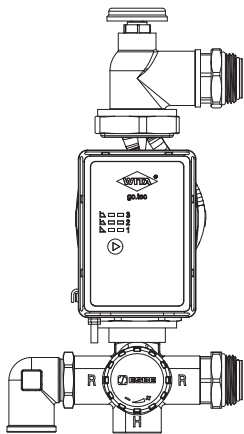

Wita Go.tec 25-7 Pump

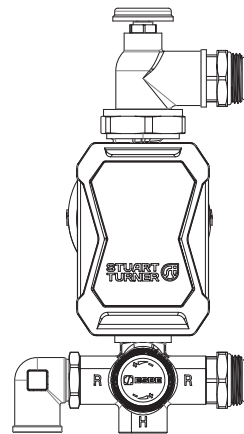

Stuart Turner 25/6 Pump

ESBE T4 Underfloor Heating Pump Control Set with Thermostatic Mixing Valve

Installation and Commissioning Manual

Contents

1. Key symbols and safety instructions.....	3	5. Installation	12
1.1 Key to symbols	3	5.1 First fix installation	12
1.2 General safety instructions	3	5.2 Changing the handing	12
2. Appliance information	4	5.3 Mechanical installation	13
2.1 General information	4	5.4 Setting the mixed outlet temperature.....	14
2.2 Intended use	4	5.5 Electrical installation	15
2.3 Misuse	5	6. Commissioning	16
2.4 Declaration of conformity	5	6.1 Pre-commissioning checklist.....	16
2.5 Assembly components + spare part codes	6	6.2 Pressure test	16
2.6 Hydraulic connections	6	6.3 Venting the system	16
2.7 Assembly Dimensions	7	6.4 Operational test.....	16
2.8 Schematic layout.....	9	6.5 Water quality & pipe corrosion.....	16
2.9 Technical & performance specification.....	9	6.6 Handover	19
3. Regulations.....	9	7. Appendix	20
3.1 General.....	9	7.1 T4 Pressure Drops.....	20
3.2 Standards and guidelines	9	7.2 Grundfos Pump curves and technical.....	20
3.3 Inspection and maintenance.....	10	7.3 Wilo Pump curves and technical.....	23
4. Pre-installation requirements	10	7.4 Stuart Turner Pump curves and technical.....	25
4.1 System preparation	10	7.5 Wita Pump curves and technical	26
4.2 Cleaning primary system	10	7.6 Replacing the pump	27
4.3 Clearances	10	7.7 Replacing the internal mixing components	27
4.4 Location.....	10	7.8 Fault finding	28
4.5 Checking the pump curve.....	11	7.9 Product guarantee.....	28
4.6 Checking the valve selection.....	12		

1. Key symbols and safety instructions

1.1 Key to symbols

Warnings

	Warnings in this document are identified by the warning triangle adjacent. Keywords are used at the start of a warning triangle to indicate both the type, and seriousness of the risk identified, if measures to prevent the risk are not taken.
---	---

Essco Group have defined the following Keywords and used them in this document:

- **NOTICE** Indicates a situation that could result in damage to property or equipment.
- **CAUTION** Indicates a situation that could result in minor to medium injury.
- **WARNING** Indicates a situation that could result in severe injury or death.
- **DANGER** Indicates a situation that will result in severe injury or death.

1.2 General safety instructions

Follow these guidelines:

- Adhere to national and regional regulations, technical rules, and guidelines always.
- Observe the safety instructions and warnings identified and take appropriate care.
- Before starting the installation, any installation instructions (manifold, pump pack, heating controls, etc.) should be carefully read through.
- Record all work carried out.

Risk of electrical shock

- Due to risk of electrical shock any electrical work or maintenance must only be carried out by qualified / registered person.
- Before carrying out any work on electrical components, isolate them from the power supply (230V AC) (fuse, circuit breaker) and secure against unintentional reconnection.

Appliance operation

Cleaning and user maintenance should only ever be carried out by competent and authorised personnel.

Important handling instructions

- Care should be taken when transporting, lifting, and carrying the appliance.
- The correct method for handling heavy objects should be strictly observed.

General handling guidelines

Only remove packaging at the time of the final installation to protect products from damage. Dispose of packaging materials appropriately.

Packaging

The following points should be observed during unpacking:

- Check the delivery immediately upon receipt for completeness and transport damage.
- Carefully unpack the unit.
- In the event of transport damage, the delivery should only be accepted conditionally.
- Do not use damaged components for assembly.

Siting and installation

Correct siting, assembly and installation of the product are fundamental requirements for safe and economical operation of the appliance.

- Only trained contractors are to site and install the appliance and its components.
- The appliance must only be installed in rooms and locations that meet the manufacturers' requirements.

Commissioning

- The appliance and the components must only be commissioned by a competent person.
- Commissioning reports should be completed during commissioning and kept as record documents after completion.
- Check all connections for leaks prior to starting up the heating system.
- All fixings and fittings must be checked and tightened after the unit has been installed as required.
- Following commissioning of the system, where inspection works are conducted, a final inspection checklist shall be completed and kept on site and made available for any interested parties.

Risk of damage due to operator error

Operator errors can result in injury and damage to property.

- Ensure that only personnel who can operate this appliance correctly have access to it.
- Inspection, maintenance, and repairs must only be carried out by competent people.
- Use only original spare parts from the manufacturer. The manufacturer can assume no liability for damage caused by spare parts not supplied by the manufacturer. A spare parts guide can be found in the appendix of this installation operations manual.

Electrical work

Electrical work must only be carried out by a qualified electrician.

Before starting electrical work:

- Ensure that the electricity supply is safely isolated and secure to prevent inadvertent reconnection.
- Information on safe isolation can be found in the Health and Safety Executive Guidance HSG85.

- Using test equipment approved to GS38 confirm that the electricity supply is disconnected.
- Refer to the manufacturer's information when installing other components with Essco equipment within the system.

Danger of burns and scalds

- Surfaces of individual components, connections and leaking water can be very hot and cause severe burns and scalds.
- Do not touch hot surfaces.
- Caution should be taken not to touch any leaking water or drained system water unless the temperature is known and safe.

Leakage

If leaks are observed:

- Immediately close all isolation valves.
- Ensure all leaks are repaired by a suitably qualified professional.

2. Appliance information

2.1 General information

Main features

- High quality ESBE 4-port mixing valve providing as standard:
 - Scald safe temperature control for protection of UFH pipes and floor coverings¹.
 - Accurate and stable temperature control within $\pm 3^{\circ}\text{C}^1$.
 - Low 20°C flow temperature setting specifically designed to meet requirements of BS EN 1264 warm-up procedure.
- Compact design requiring only minimal installation space and clearances.
- High flow characteristic of 3.4 kvs permits higher flow rates and reduced pressure drops.
- Temperature gauge on mixed secondary flow as standard.
- Quick manifold attachment through use of integral spinning nuts.
- Integral check valve for fast filling of UFH manifolds.
- Self-sealing connections for leak reduction.
- Option to replace temperature gauge with high limit flow temperature sensor.
- Full reversible design for left or right-handed installation, with top or side entry connections also possible.
- Choice of A-Rated ErP compliant circulation pumps from established UK market leaders.
- Available with 200mm, 210mm or 225mm centres to suit wide range of UFH manifolds.
- Fully assembled, tested, and supported in the UK.
- 2-year warranty as standard.

¹ **Temperature stability:** Valid at unchanged cold/return water pressure, minimum flow rate 9 l/min, and ΔT of 3 – 10°C.

Please Note: As the pump choice is driven by end user and will vary, for any “generic” hydraulic illustrations the pump shown also varies in this document.

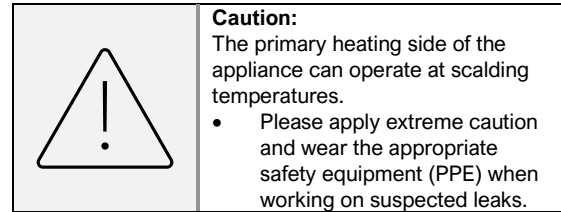

Instructing the customer

- When handing over, instruct the user how to operate the heating system and inform them about its operating conditions.
- Draw the user's attention to any safety-relevant action.
- Explain that modifications and repairs must only be carried out by an authorised contractor.
- Hand customers the appliance documentation for safekeeping.

2.2 Intended use

The T4 Pump Pack is a pre-assembled temperature control and circulation group designed for connection onto an Underfloor Heating Manifold, which is fed from a higher temperature primary circuit. The Pump Pack provides scald safe mixed flow temperature control and circulation to UFH circuits serving multiple zones, providing the flow rate and temperature are within stated limits.

The assembly comprises 4-Port mixing valve, circulation pump, check valve, temperature gauge, and spinning nuts. Further components (build specific) can also include elbow fitting and high-limit sensor where required.

The circulation pump requires a live switch to run when there is heating demand, which is typically provided by room thermostat, or UFH control unit where multiple zones are present. There is no balancing of flow rate on the pump pack, and as such external balancing is required.

Please refer to Technical & Performance specification to ensure correct use of this appliance.

The manifold is a separate component covered elsewhere, and should include:

- At least two stop valves and a balancing device, per floor circuit. The shut-off and balancing functions shall be independent.
- At least one circuit per heated / cooled room shall be installed in order to permit temperature control to be either manual or automatic.

Note:

The purpose of installing a balancing device in each circuit is to make sure that each circuit gets its design medium flow rate under design conditions as calculated in the design procedure (see ISO 11855-3). If other equipment within the heating and cooling system produces the same effect, it is acceptable to install and use this equipment instead of balancing devices, only with the precondition that the effect is verified by testing or calculation performed by approved institute.

2.3 Misuse

Appliance must be used as per the Intended Use statement. Operation outside the parameters of the intended use is considered misuse and could cause harm to people and damage to property.

Using the appliance outside of its intended use may also invalidate the manufacturers guarantee.

2.4 Declaration of conformity

This product, in design and operation, conforms to the European Directives and supplementary national requirements. Compliance is demonstrated by the CE marking. You can request the declaration of conformity for the product. To do so, send your request to the address on the back of the manual, or contact your local sales representative.

2.5 Assembly components + spare part codes

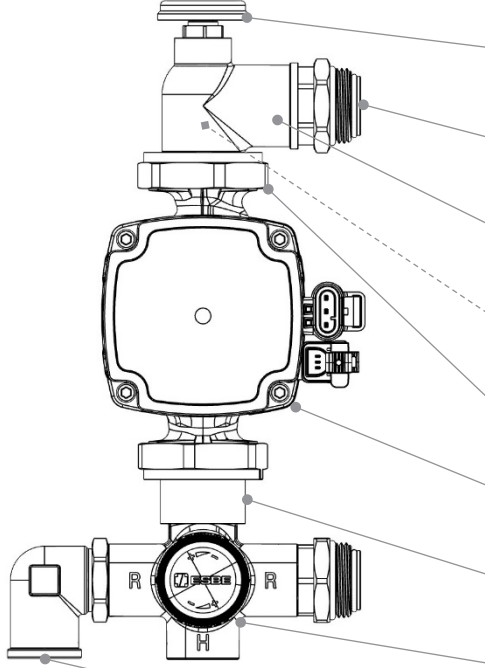
	#	Product Code (Spare Parts only)	Component Description
	1	EGPPAB-001	3/8" x Ø40 Self-sealing temperature gauge. Male BSP thread, centre back entry. Scale 0-80°C
	2	EFPPCB-001	3/4" x 1" M Nickel plated self-sealing spinning nut (PN10)
	3	EFPPAA-001	3/4" F x 42mm Flanged nickel plated brass T-Piece to suit 1 1/2" pump. 3/8" Pocket for gauge (PN16)
	4	EVPP03-001	25mm Diameter NBR Check valve. Flow rate 28-125 l/m (WRAS)
	5	EFPPCA-001	1 1/2" Nickel plated pump flange with 53mm nut (PN16)
	6	EC00XX-0XX	A-Rated ErP compliant circulation pump
	7	EFPPBA-00X	1" F x 1 1/2" Pump flange x XXmm Nickel plated flange, for XXmm c/c manifolds (PN16)
	8	31810100	ESBE VTG141 20-55°C RP3/4-G1 20-3,4
9	EFPPBB-001	3/4" M (+O-Ring) x 3/4"F nickel plated brass elbow (PN16)	

2.6 Hydraulic connections

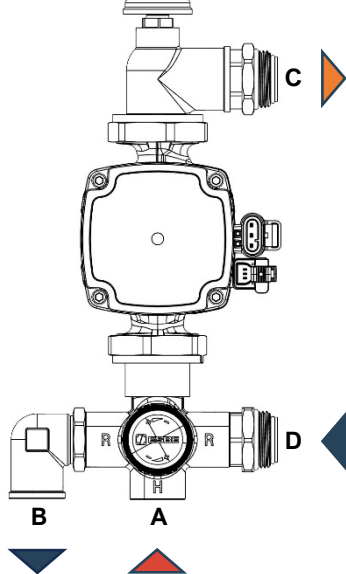
	PRIMARY	3/4" x F BSP	A	Primary flow
			B	Primary return
	SECONDARY	1" x M BSP	C	Manifold flow (mixed)
			D	Manifold return

2.7 Assembly Dimensions

Grundfos Circulation Pump

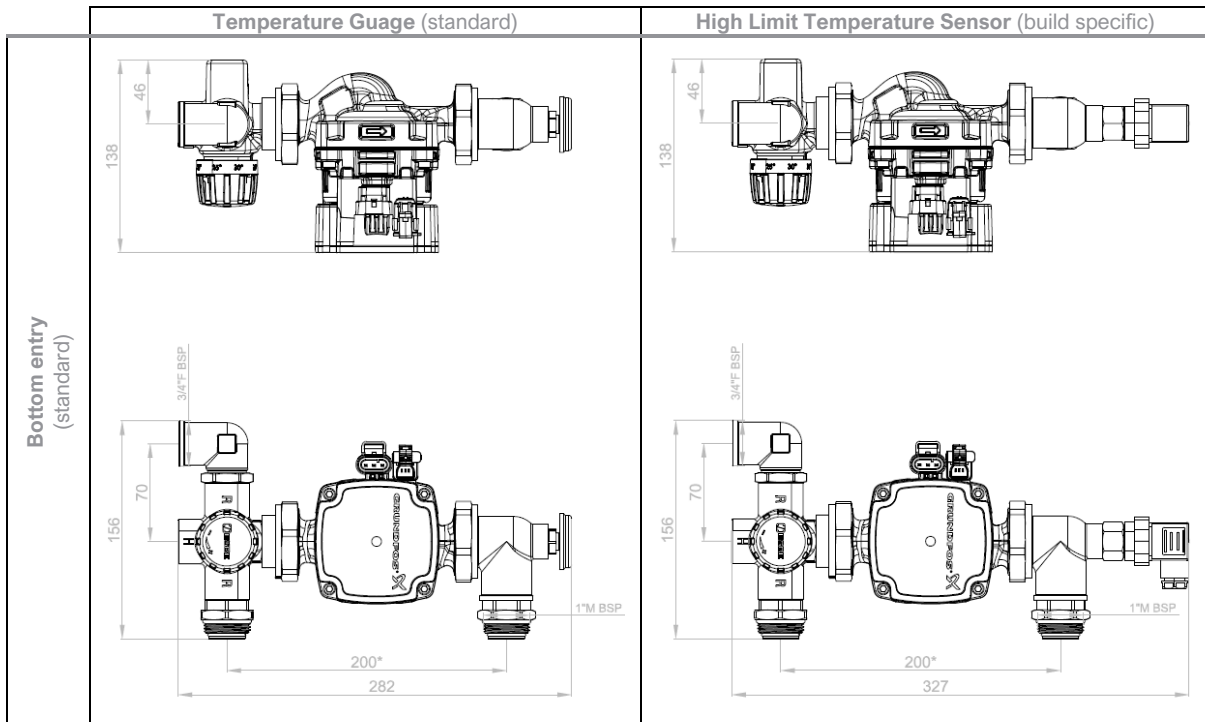

Wilo Circulation Pump

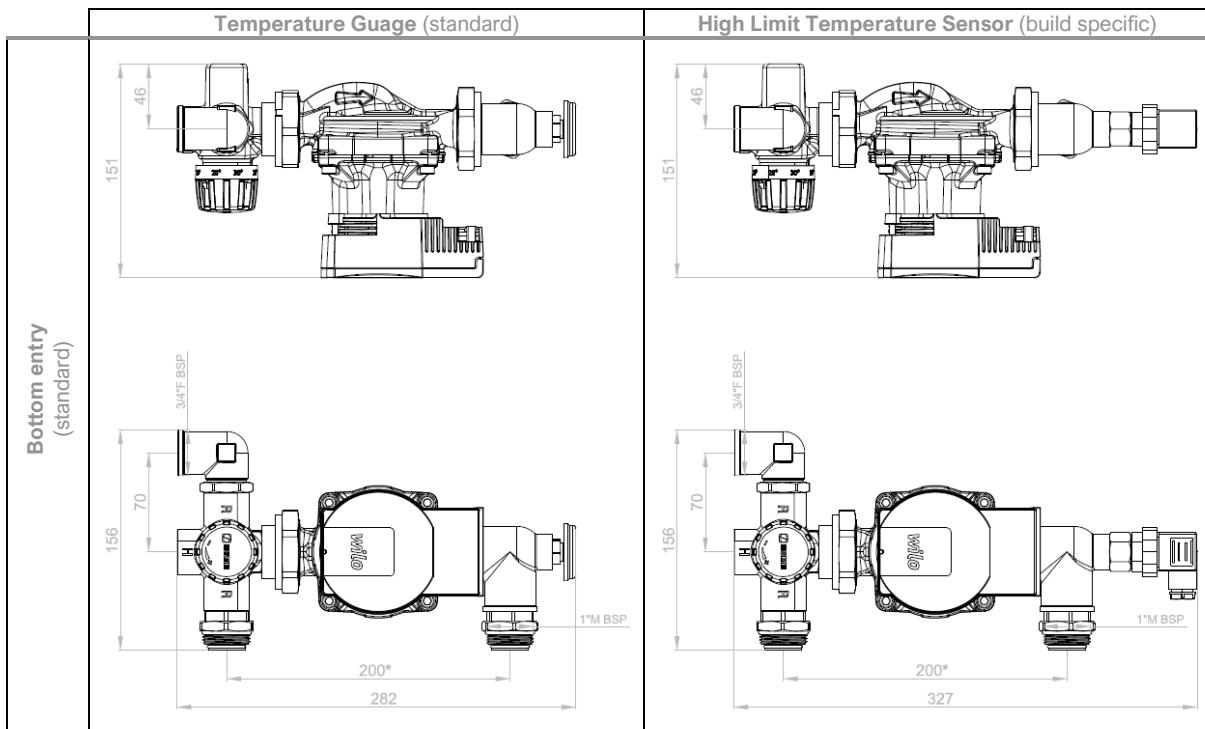

Stuart Turner Circulation Pump

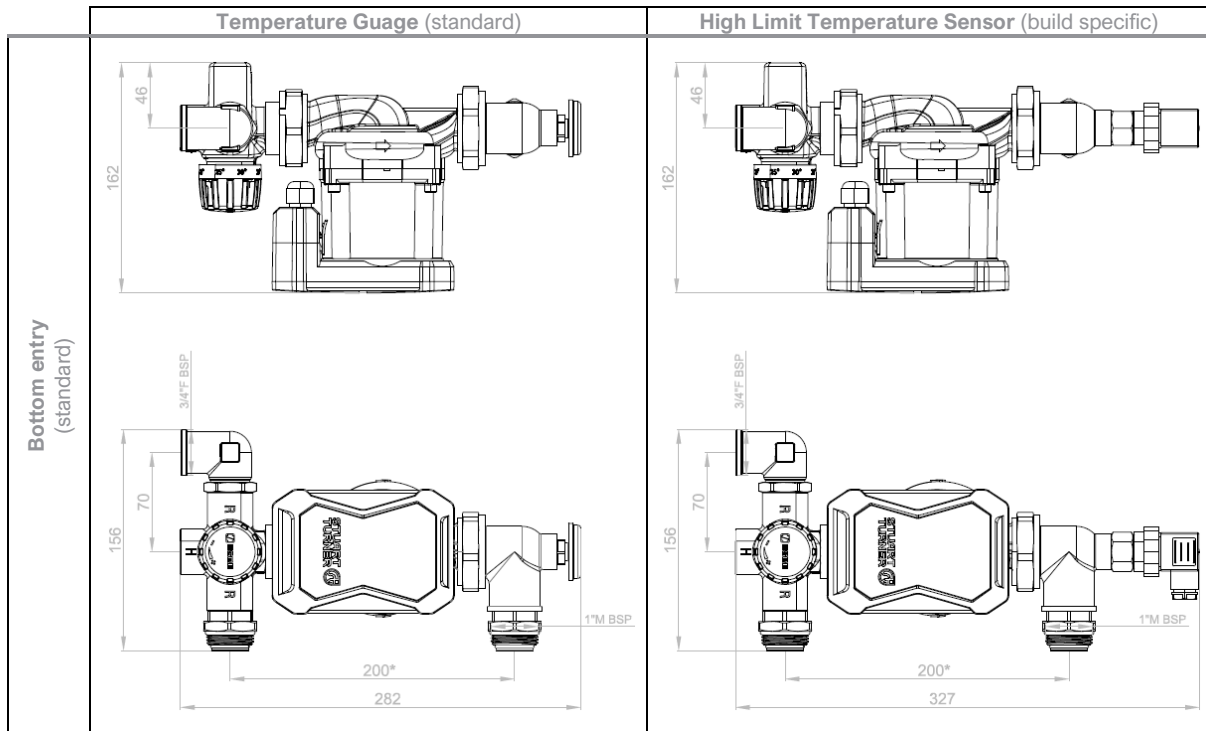

WITA Circulation Pump

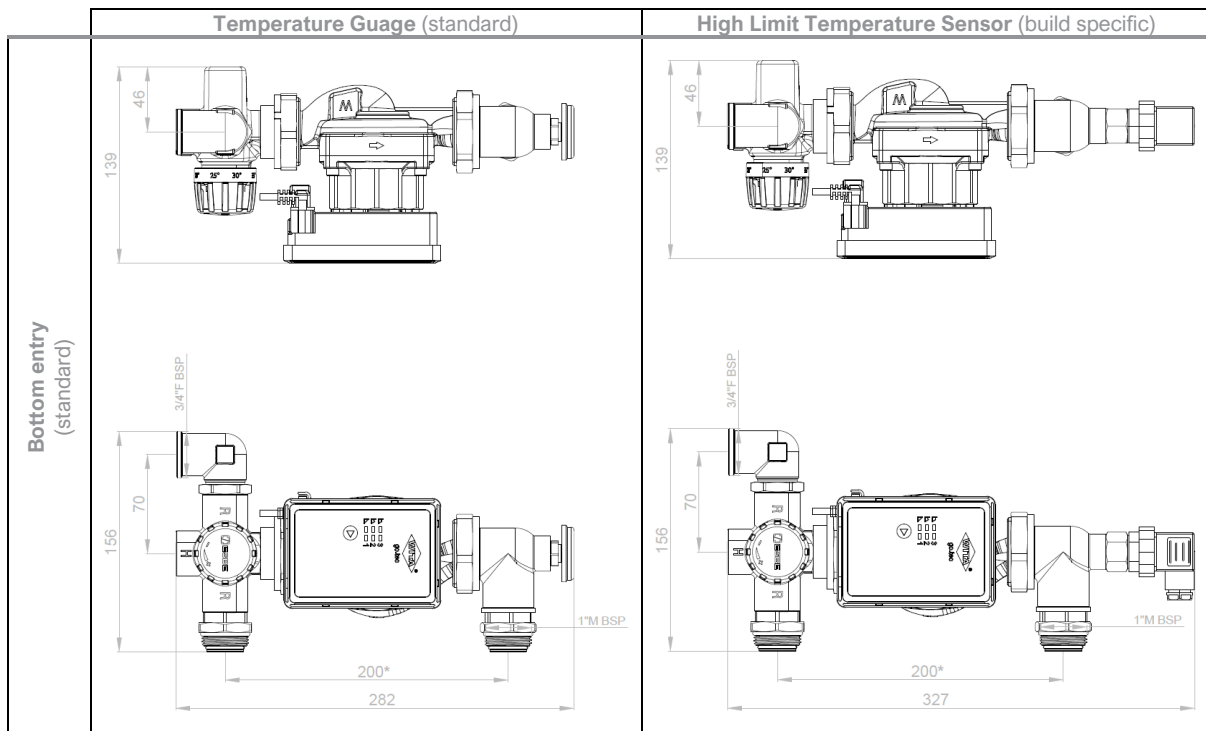

2.8 Schematic layout

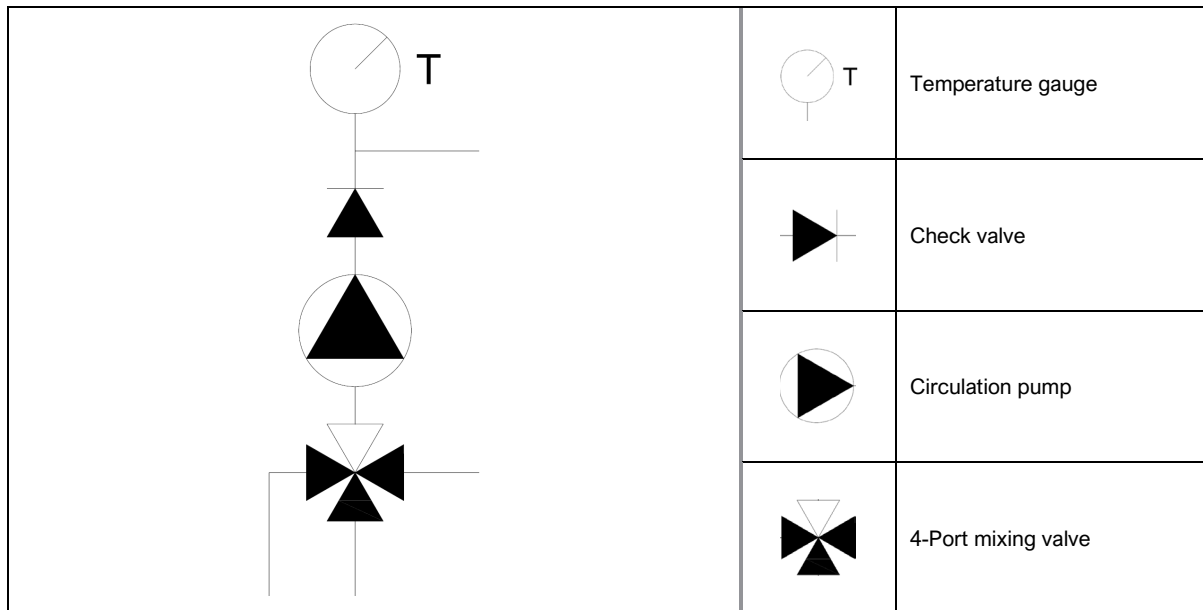

2.9 Technical & performance specification

Specification	
Medium	Heating water to VDI 2035, glycol solutions
Max. percentage of glycol	< 50%
Max. working pressure	PN10
Max. differential pressure	1 bar
Min. recommended pressure	3 kPa
Working temperature range	0 - 80°C
Adjustable temperature range	20 - 55°C
Factory preset temperature	55°C
Temperature stability	± 3%
Minimum flow rate for stability	9 l/m (0.15 l/s)
Recommended range of temperature differential	3 - 10°C
Secondary side connections for manifold	1" M
Primary side TMV connections	¾" F

*Temperature stability: Valid at unchanged cold/return water pressure, minimum flow rate 9 l/min, and ΔT of 3 – 10°C.

3. Regulations

3.1 General

The installation and maintenance of the unit must be performed by a qualified person in accordance with regulations and rules of the local area where installation is to take place.

3.2 Standards and guidelines

The multi-part British Standard BS EN 1264 covers design and installation requirements relating to Water Based Surface Embedded Heating and Cooling Systems. From this standard, there are two sections which relate to this appliance:

BS EN 1264 Part 5 Installation

- Section 5.1.2.4.1 – **Safety:** "For heating systems, a safety device, independent of the control unit, and which operates even in the

absence of electrical power, shall cut off the heat supply in the floor heating circuit in such a way that the temperature around the heating elements does not exceed the data given in 5.1.2.8.2".

- Where applicable, this safety device could be fitted to the T4 pump pack, but it may also be fitted to the UFH manifold instead.
- Section 5.1.4 – **Initial heating up:** "The initial heating up commences at a flow temperature between 20 °C and 25 °C which shall be maintained for at least three days. Subsequently, the maximum design temperature shall be set and maintained for at least a further four days. The process of heating up should be documented".
 - The T4 pump pack can be set from 20°C to ensure compliance with this design standard when documenting the warm-up procedure.

- The warm-up procedure is designed to ensure moisture is not removed from the screed too quickly, as doing so can often result in cracks and other issues.

3.3 Inspection and maintenance

The heating system should be inspected regularly for the following reasons:

- To achieve and maintain a high efficiency.
- To ensure operational safety.

The recommendation from BSRIA BG4/2011 is that underfloor heating manifolds are checked annually for signs of leaks. If leaks are found and can't be resolved by tightening the fittings, the manifold may need to be dismantled and the gaskets or seals replaced. The operation of the manifold valves should also be checked, and the indicated flows compared to the original commissioning records. Should it be necessary to flush the pipe through for whatever reason, this can usually be done by disconnecting the loop(s) from the manifold and using potable water at sufficient mains water pressure. Water quality should be checked frequently, and any strainers also checked/emptied as often as required. The thermostatic control valve should be isolated during flushed through and not flushed through, to prevent dirt and debris blocking the valve.

4. Pre-installation requirements

4.1 System preparation

- Any plastic pipework used on the central heating system must have a polymeric oxygen barrier coating and at least 1000mm length of copper or steel pipe connected to the appliance.
- Plastic pipework used for under-floor heating must be correctly controlled and must not exceed the under-floor manufacturers' specifications.
- The under-floor heating design should not exceed the hydraulic capacity of the circulation pump.
- Drain cocks are required at the lowest points on the system.
- Air vents are required at the highest points on the system.
- To protect the under-floor circuit in the event of a failure condition, a high limit thermostat must

be fitted onto the flow pipe to the under-floor circuit and wired into the control unit. This switches off the central heating pump in the event of an over temperature condition.

	<p>Notice: Underfloor heating circuits. Damage caused by excessive flow temperature.</p> <ul style="list-style-type: none"> • Ensure the flow temperature does not exceed the requirements of the underfloor heating circuit manufacturer.
--	--

4.2 Cleaning primary system

	<p>Notice: Risk of damage to system or appliance. Debris from the system can damage the appliance and reduce efficiency. Failure to comply with the guidelines from the use of water treatment with the appliance will invalidate the appliance warranty.</p> <ul style="list-style-type: none"> • Before installation, ensure that the central heating system is cleaned and thoroughly flushed in accordance with the standards and guidelines of the country of installation. • The thermostatic control valve should be isolated and not flushed through.
--	---

4.3 Clearances

We recommend that once the pump pack is fitted to the manifold, and the manifold wall mounted, at least 300mm clearance is given from the top of finished floor, to bottom of pump pack. We also recommend 100mm clearance is left above and at either side of the manifold / pump pack, for ease of future maintenance.

4.4 Location

Manifolds are typically situated within either utility rooms, airing cupboards, cloakrooms or an understairs cupboard, and should be easily accessible for future maintenance and servicing. Ideally located centrally within the home to allow for a simple layout of pipework loops. The pump pack is not suitable for external installation.

4.5 Checking the pump curve

When selecting a circulation pump for a closed loop system (see Appendix), the static elevation is not accounted for in head-pressure calculations as these systems are largely unaffected by static pressure. It is important however to review:

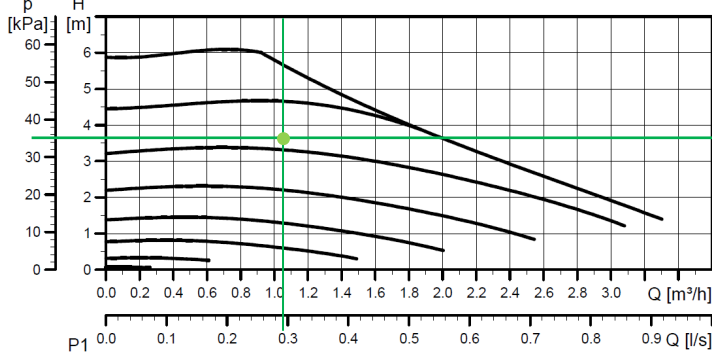
<p>System flow rate (m³/h) – summation of circuit flow rates at manifold</p>	<p>System pressure drop (m) – summation of pump pack, manifold bars, valves, pipework</p>
$\dot{m} = \frac{Q}{(C_p \times dT)}$	<p>Example: Total system pressure drop = 35 kPa Converting units: kPa > m = 35 x 0.101997 = 3.567 m</p>
<p>Where: <i>m</i> = mass flow rate (kg/s) <i>Q</i> = energy (kW) <i>C_p</i> = specific heat capacity (kJ/kg/°C) <i>dT</i> = differential temperature (°C)</p> <p>Example: Total energy = 12 kW F/R = 50/40 °C => dT = 50-40 = 10 °C => MWT = (50+40) / 2 = 45 °C C_p at 45°C = 4.180 kJ/kg/°C Density at 45°C = 0.990 kg/l</p> $\dot{m} = \frac{12}{((4.180 \times 0.990) \times 10)} = 0.290 \text{ kg/s}$ <p>Converting units: kg/s > m³/h = 0.290 x 3.6 = 1.044 m³/h</p>	<p>Checking pump curve –</p> 

4.6 Checking the valve selection

Calculate kv of valve required to check compatibility of T4 spec:	Calculate permissible flow rate based on a max. pressure drop and use of T4:	Calculate pressure drop of T4 at the minimum required flow rate (9 l/m):
$kv (m^3/h) = \frac{Q}{\sqrt{\Delta P}}$	$Q (m^3/h) = kv \sqrt{\Delta P}$	$\Delta P (bar) = \left(\frac{Q}{kv}\right)^2$
<p>Example: Q, design flow rate = 0.21 l/s ΔP, pressure drop = 6 kPa</p> <p>Converting units: l/s > m³/h = 0.21 x 3.6 = 0.756 m³/h kPa > bar = 6 x 0.01 = 0.06 bar</p> <p>Find Kv of valve required using formula:</p> $kv (m^3/h) = \frac{0.756}{\sqrt{0.06}} = 3.09 m^3/h$ <p>VTG is suitable at kvs 3.4 m³/h</p>	<p>Example: Max. pressure drop = 25 kPa T4 pack selected => kvs = 2.5 m³/h (taken from appendix 7.1)</p> <p>Converting units: kPa > bar = 25 x 0.01 = 0.25 bar</p> <p>Find flow rate permissible using formula:</p> $Q (m^3/h) = 2.5 \sqrt{0.25} = 1.25 m^3/h$ <p>Converting units: m³/h > l/s = 1.25 / 3.6 = 0.347 l/s Equates to 14.37 kW at 10 °C dT</p>	<p>Example: Q, design flow rate = 9 l/m T4 pack selected => kvs = 2.5 m³/h (taken from appendix 7.1)</p> <p>Converting units: l/m > m³/h = 9 x 0.06 = 0.54 m³/h</p> <p>Calculate pressure drop of valve at design flow rate using formula:</p> $\Delta P (bar) = \left(\frac{0.54}{2.50}\right)^2 = 0.047 bar$ <p>Converting units: bar > kPa = 0.047 / 0.01 = 4.7 kPa</p>

Calculate the valve authority falls between 20-50%	
$N (\%) = \frac{\Delta P_v}{(\Delta P_v + \Delta P_c)}$	<p>Example:</p> <p>System pressure drop (ΔP_v) = 6 kPa Valve pressure drop (ΔP_c) = 2 kPa</p> <p>Find valve authority using formula:</p> $N (\%) = \frac{2.07}{(2 + 6)} = 25.9\%$

5. Installation

5.1 First fix installation

Depending on where the manifold and T4 pump pack are installed, the following requirements must be fulfilled:

- Walls or ceilings must be structurally capable of supporting the system.
- Tolerances, levels, and datum must comply with national standards where these exist.
- All electrical cables, ducts or service pipes must be installed and tested before heating/cooling work commences.



5.2 Changing the handing

LB *	LS	RB	RS
Left-handed bottom entry	Left-handed side entry	Right-handed bottom entry	Right-handed side entry

* The pump pack is supplied in the **left**-handed orientation, with **bottom** pipe entry as standard ('LB').



This can be changed to suit the installation as required so we recommend doing this prior to fitting to the UFH manifold. To change primary connections from bottom to side entry, the elbow is simply moved from the outlet port to the inlet port.

To change the manifold handing from left to right-handed, the process is as follows:

		
<p>Unscrew lower spinning nut and elbow from the mixing valve and refit them on the opposite side of the pack.</p>	<p>Loosen the top pump flange and spin the upper assembly 180 degrees.</p>	<p>Check and tighten all fittings, before assembling to the manifold.</p>

5.3 Mechanical installation

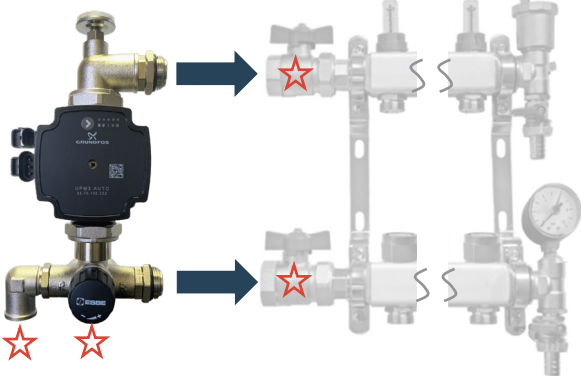
The T4 Pump Pack assembly is designed to be attached to a distribution type UFH manifold. The manifold and associated brackets must therefore be suitably load-bearing to support the weight of this appliance without deflection or risk of detachment from the surface it's being secured to. Please refer separately to the manufacturer's manifold instructions for further detail.

	
<p>To attach to the manifold, the assembly is first offered up to the UFH manifold to check the alignment of the pump pack connections correlate to the manifold bar connections.</p> <p>This will either be to the left, or right of the manifold; depending on the chosen handing. At this stage the handing of the pump pack will have already been taken into consideration and the assembly altered as necessary.</p>	<p>The spinning nuts are designed for quick manifold connection and once in position can be screwed into the bars and hand tightened.</p> <p>A 37mm AF spanner ('across flats' type) can then be used to tighten this connection as required, noting that care must be taken not to over-tighten the spinning nuts, as this can damage to the seals. The use of a 31mm AF spanner will also ensure that the connection to the pump mixer is kept tight.</p>
<p>★ For ease of maintenance, isolation valves are recommended below the pump pack and before the manifold.</p>	

	<p>Note: The pump head must face forward as indicated adjacent. This should be considered if/when the manifold is not wall mounted.</p>
---	---

5.4 Setting the mixed outlet temperature

The mixed outlet temperature can be set at any time, but to verify the mixing valve is controlling to this temperature correctly, the system must be filled, and electrical wiring completed with a heating demand signal and pump circulating.

1	Calculate the optimal system design temperature required to achieve peak design load.	2	3	Use the temperature gauge to check and verify the mixed outlet temperature is achieved.
				

5.5 Electrical installation

For site specific wiring details, refer to underfloor heating design drawings. For general guidance of single and multi-zone wiring details please see below.

Single zone wiring guidance:

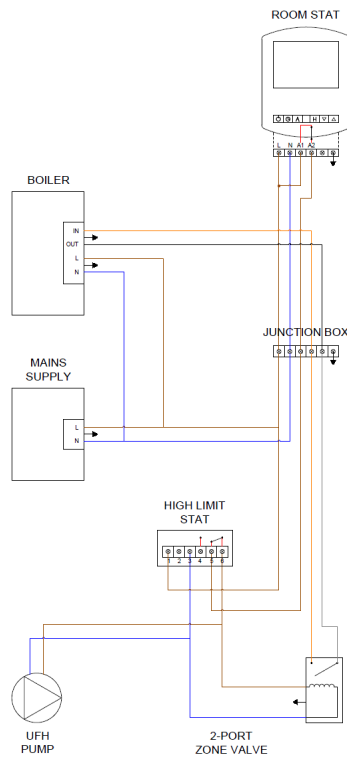

Multi-zone wiring guidance:

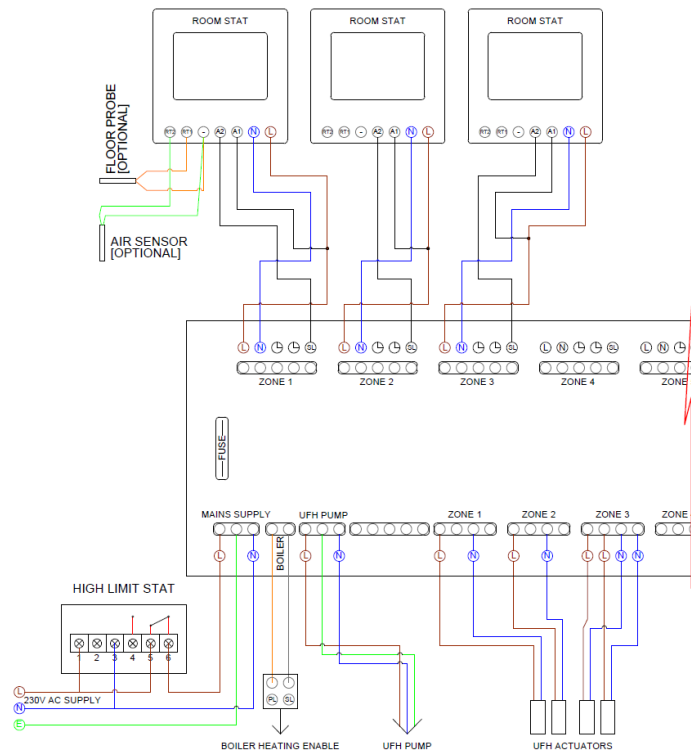

6. Commissioning

6.1 Pre-commissioning checklist

Checklist		Complete
1	Heat network or plant room fully operational and complete (Inc. flushing & water treatment). *	
2	Fully pressure test and flush mains cold-water network with water and/or air, in accordance with BS EN 806-4, selecting the correct test method based on the material and size of the installed pipes.	
3	Pipework to manifold, and UFH pipework sized correctly for design flow rates	
4	Circulation pump selected correctly using peak load system pressure drop and flow rate	
5	T4 Pump pack fitted as per the hydraulic connections	
6	All connections tightened in readiness for pressure testing	
7	UFH design temperature calculated and required adjustment dial setting noted / set accordingly	
8	If screeding , dial set to required setpoint to commence warm-up procedure (20-25°C)	
9	Pump connected to mains switch, and tested to switch correctly based on demand signal	
10	UFH installation and manifold checklists completed as per manufacturer's instructions	

* The pipework systems connected to any pump pack must have been cleaned and flushed in accordance with the relevant standards and regulations.

While guidance from CIBSE CP1 2020 has been summarised later in sections 6.5 and 6.6, engineers should refer to this guide, BSRIA BG29/2020 & VDI-2035 European water quality standards in full, for complete guidance on water quality requirements.

6.2 Pressure test

A leak test is required post installation of the UFH system. BS EN 1264 states that this test can be carried out with water or compressed air as test medium, but prior to screeding the test pressure must not be less than 4 bar, or not greater than 6 bar for standard systems. The absence of leaks and the test pressure shall be specified in the test record.

6.3 Venting the system

Air inside the assembly is transported by the liquid into the system shortly after startup. It must be possible to vent the system at the highest part of each system segment, to remove any air. It's recommended that the pump should run for a period not less than 2 hours to vent the system fully. It is also recommended that the pump runs for a period every day to reduce risk of it seizing.

6.4 Operational test

The system should be fully tested to ensure each zone thermostat controls the correct actuators, and that the design flow rates and temperatures are achieved.

6.5 Water quality & pipe corrosion

Initial fill with mains water and chemical treatment used in operation:

Parameter	Units	Control limit	Monitoring frequency	Reasons for using this parameter
Visual	-	Clear with no suspended solids or gassing	Monthly	A photograph of the system water in a clear container should be taken as soon as possible following sampling. An extended period before a visual check can lead to changes in appearance, e.g., precipitation of dissolved iron when contacting with oxygen.
Odour	-	No strong sulphurous or ammoniacal smell	Monthly	Sulphide smells indicate potential growth of sulphide-reducing bacteria (SRB). Ammonia smells can indicate growth of nitrate-reducing bacteria (NRB) (some inhibitors have a mild ammonia smell).
pH (Control range defined by least noble part of system metallurgy)	-	Aluminium < 8.5 Iron-based 9.2 – 10.0 Copper and brass 7.5 – 10.0	Weekly (or continuous)	Sudden changes in pH can indicate changes in system water quality, therefore continuous monitoring is advised. pH control should be based on the metallurgy of the system.

				Note: Where aluminium and steel are used in the same system the pH value shall be less than 8.5 to avoid corrosion of the Aluminium.
Conductivity	µS/cm	See note 1	Weekly (or continuous)	Sudden changes in conductivity can indicate changes in system water quality, therefore continuous monitoring is advised.
Oil and grease	mg/l	Not present	Annually	Oil and grease being present indicates contamination of the system water.
Chloride measured at 80°C	mg/l	< 100	Monthly	Excess chlorides in the heat network will increase the potential for corrosion, particularly stress corrosion cracking in stainless steels and dezincification in brass fittings.
Sulphate	mg/l	-	Monthly	Monitoring of trends recommended as changes can indicate bacterial growth
Iron total	mg/l	< 15.0 (see note 2)	Monthly	Monitoring of trends recommended as changes can indicate potential corrosion issues.
Iron dissolved	mg/l	< 3.0	Monthly	Monitoring of trends recommended as changes can indicate potential corrosion issues.
Copper dissolved	mg/l	< 1.0	Monthly	Monitoring of trends recommended as changes can indicate potential corrosion issues.
Aluminium total	mg/l	<1.0	Monthly	Monitoring of trends recommended as changes can indicate potential corrosion issues. Only relevant if aluminium used in the system.
Calcium hardness	mg/l	See note 3	Monthly	High levels of hardness in the system will increase precipitation of calcium carbonate scale onto heat exchanger surfaces, which will reduce efficiency. It also increases the surface temperatures of the exchangers, which may lead to the potential for stress corrosion.
Total alkalinity	mg/l	> 250, < 1250	Monthly	Low levels of alkalinity indicate a lack of protection against corrosive water. High levels of alkalinity indicate the potential for caustic embrittlement.
Ammonia	mg/l	<30	Monthly	Increasing trend of ammonia in the system water is an indication of bacteria growth.
Oxygen	mg/l	See note 4	Monthly (or continuous)	Increases in dissolved oxygen content indicates ingress of oxygen which will potentially drive corrosion, therefore continuous monitoring is advised.
Suspended solids	mg/l	< 30	Monthly	Suspended solids indicate poor system water quality and further filtration, and treatment is required.
Settled solids	mg/l	As defined in BSRIA BG 29/2020 and BS 8552: 2012 – limits as specified for pipework at extremes of the system and for terminal units.	Monthly	Not all detrimental solids are in suspension, therefore it is also essential to test for settled solids. Settled solids can reduce flow rate and can lead to greater risk of corrosion.
Inhibitor(s)		Inhibitor levels should be checked in accordance with the water treatment specialist's and manufacturers' guidance.	Monthly	Inhibitor reserves should be monitored to ensure adequate reserves are present to minimise the potential for corrosion.
TVC (Total viable count)	cfu/ml	<10,000 at 30°C and no increasing trend	Monthly	Increasing trends of bacteria indicate poor water quality.
Pseudomonads	cfu/ml	< 1,000 at 30°C and no increasing trend	Monthly	Increasing levels of pseudomonads indicate poor water quality and potential biofilm production.
SRB (Sulphate-reducing-bacteria) at 5 days	cfu/ml	Absent	Monthly	Counts of SRB indicate poor water quality and potential for pitting corrosion under deposits and biofilms.

Note 1: Although it is important to monitor conductivity, a hard limit is not considered necessary.

Note 2: This value is from Table 5 of BG29/2020 (BSRIA, 2020), which also states that lower limits may be used.

Note 3: Total hardness will depend on the amount and type of softening applied.

Note 4: Oxygen limits are not defined in BG 29/2020 but should be as low as possible. BG 50/2013 (BSRIA, 2013) states that a value > 2 mg/l would indicate a problem with air entering the system.

Initial fill with demineralised water with controlled pH within VDI parameters:

Parameter	Units	Control limit	Monitoring frequency	Reasons for using this parameter
Visual	-	Clear with no suspended solids or gassing	Monthly	A photograph of the system water in a clear container should be taken as soon as possible following sampling. An extended period before a visual check can lead to changes in appearance, e.g., precipitation of dissolved iron when contacting with oxygen.
Odour	-	No strong sulphurous or ammoniacal smell	Monthly	Sulphide smells indicate potential growth of sulphide-reducing bacteria (SRB). Ammonia smells can indicate growth of nitrate-reducing bacteria (NRB) (some inhibitors have a mild ammonia smell).
pH (Control range defined by least noble part of system metallurgy)	-	Aluminium < 8.2-8.5 Iron-based 8.2 – 10.0 Copper and brass 8.2 – 10.0	Weekly (or continuous)	Sudden changes in pH can indicate changes in system water quality, therefore continuous monitoring is advised. pH control should be based on the metallurgy of the system. Note: Where aluminium and steel are used in the same system the pH value shall be less than 8.5 to avoid corrosion of the Aluminium. Magnesium sacrificial anode technology may be used, which would allow a higher pH limit to be adopted.
Conductivity	µS/cm	> 50, < 100	Weekly (or continuous)	Sudden changes in conductivity can indicate changes in system water quality, therefore continuous monitoring is advised.
Oil and grease	mg/l	Not present	Annually	Oil and grease being present indicates contamination of the system water.
Chloride measured at 80°C	mg/l	< 10	Monthly	Excess chlorides in the heat network will increase the potential for corrosion, particularly stress corrosion cracking in stainless steels and dezincification in brass fittings.
Sulphate	mg/l	-	Monthly	Monitoring of trends recommended as changes can indicate bacterial growth
Iron total	mg/l	-	Monthly	Monitoring of trends recommended as changes can indicate potential corrosion issues.
Iron dissolved	mg/l	< 0.10	Monthly	Monitoring of trends recommended as changes can indicate potential corrosion issues.
Copper dissolved	mg/l	< 0.02	Monthly	Monitoring of trends recommended as changes can indicate potential corrosion issues.
Aluminium total	mg/l	-	Monthly	Monitoring of trends recommended as changes can indicate potential corrosion issues.
Total hardness	mg/l	> 10, < 200	Monthly	High levels of hardness in the system will increase precipitation onto heat exchanger surfaces, which will reduce efficiency. It also increases the surface temperatures of the exchangers, which may lead to the potential for stress corrosion.
Total alkalinity	mg/l	-	Monthly	Low levels of alkalinity indicate a lack of protection against corrosive water. High levels of alkalinity indicate the potential for caustic embrittlement.
Ammonia	mg/l	-	Monthly	Increasing trend of ammonia in the system water is an indication of bacteria growth.
Oxygen	mg/l	< 0.1	Monthly (or continuous)	Increases in dissolved oxygen content indicates ingress of oxygen which will potentially drive corrosion, therefore continuous monitoring is advised.
Suspended solids	mg/l	< 1.0	Monthly	Suspended solids indicate poor system water quality and further filtration, and treatment is required.
TVC (Total viable count)	cfu/ml	<10 for 48 hours at 37°C and 72 hours at 22°C	Monthly	Increasing trends of bacteria indicate poor water quality.
Pseudomonads	cfu/ml	-	Monthly	Increasing levels of pseudomonads indicate poor water quality and potential biofilm proliferation in the system.

SRB (Sulphate-reducing- bacteria) at 5 days	cfu/ml	Absent	Monthly	Counts of SRB indicate poor water quality and potential for pitting corrosion under deposits and biofilms.
---	--------	--------	---------	--

Note: Specialist advice should be sought when adopting the VDI 2035 approach.

6.6 Handover

- Complete commissioning reports and checklist to include as part of handover.
- Set up the appliance controls and show the customer how to operate all the controls for central heating.
- Show the customer where the serial number/appliance information is when they call in with a problem.
- Show the customer how to safely isolate the appliance if leaks are observed.
- Advise the customer that the varying external temperature will affect the output of the appliance, so changing the valve setting seasonally maybe required.
- Ensure that the installation and maintenance manual and other details are provided as part of handover.
- Where ongoing service and maintenance is offered, provide contact details in event of fault or breakdown.
- If the appliance is unused and exposed to freezing conditions, shut off all the mains supplies and drain the system and appliance, label accordingly.

7. Appendix

7.1 T4 Pressure Drops

Kv (m³/h)
2.50

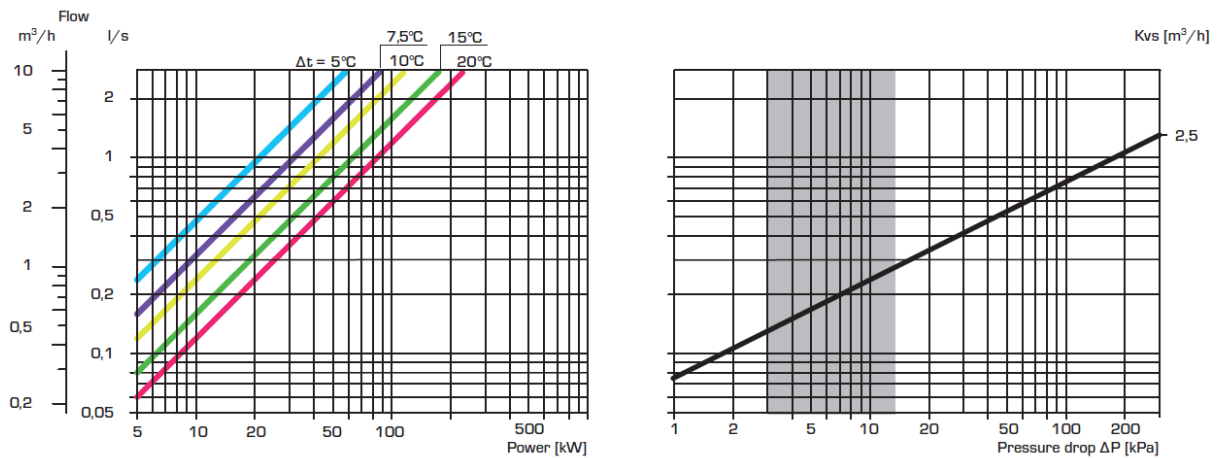

7.2 Grundfos Pump curves and technical

UPM3 AUTO was the first Grundfos self-controlled circulator with AUTOADAPT constant pressure mode, which can be used in underfloor heating systems. The UPM4 pump was later introduced.

<p>Technical details of these pumps have been summarised in the pages below. For full details visit manufacturers website, or click/scan the QR codes adjacent:</p>		
	UPM3	UPM4

Both products are suitable for the following:

- Clean, thin, non-aggressive and non-explosive liquids, not containing solid particles or fibres.
- In heating systems, the water must meet the requirements of accepted standards on water quality in heating systems, for example the German standard VDI 2035.
- The pH must be between 8.2 and 9.5. The minimum value depends on the water hardness and must not be below 7.4 at 4°dH (0.712 mmol/l).
- The electrical conductivity at 25 °C must be ≥ 10 microS/cm.
- Mixtures of water with antifreeze media such as glycol with a kinematic viscosity lower than 10 mm²/s (10 cSt). When selecting a pump, the viscosity of the pumped liquid must be taken into consideration. If the pump is used for a liquid with a higher viscosity, the hydraulic performance of the pump is reduced.

Minimum inlet pressure:

Liquid temperature	75°C	95°C	110°C
Pressure	0.005 MPa	0.05 MPa	0.108 MPa
	0.05 bar	0.5 bar	1.08 bar

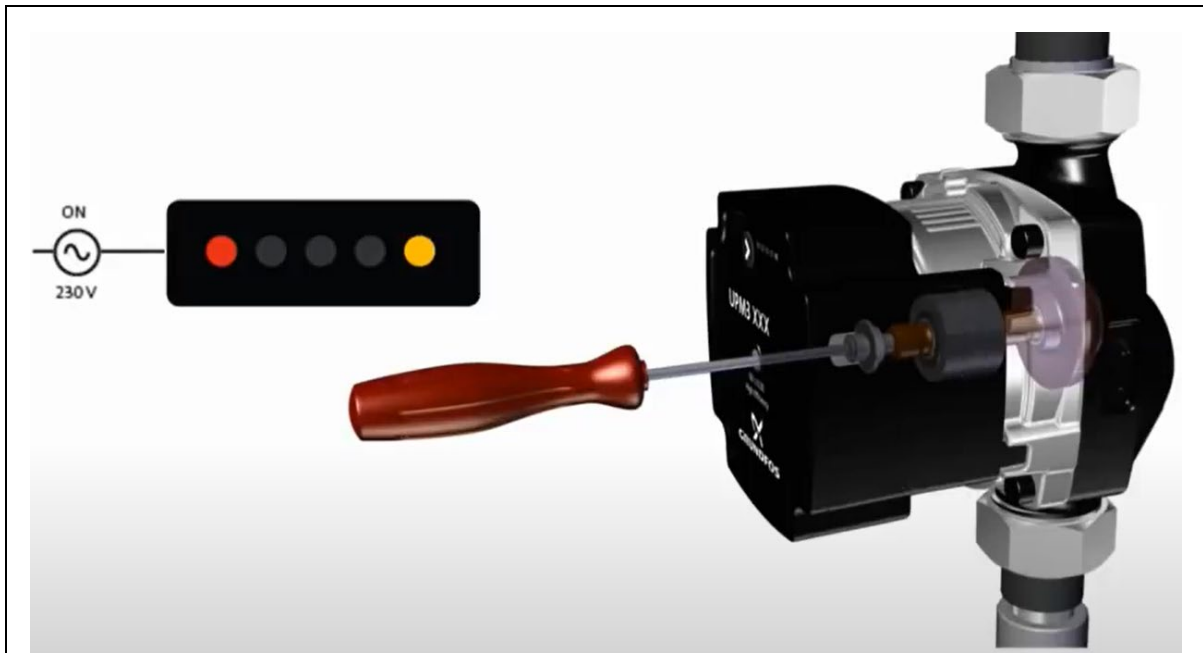

Both versions of the pump use LEDs to indicate a blocked rotor and feature a crosshead screwdriver hole to manually unblock.

To do this, a screwdriver is inserted and turned clockwise and counterclockwise.

The LEDs are then checked again to see if the fault has cleared.

Specific for Grundfos UPM3:

Operating panel		Key	
		1	Grundfos logo
		2	Grundfos pump type
		3	High efficiency indicating ECM technology
		4	QR Code to Grundfos data matrix
		5	Customer product number or barcode
		6	Push button
		7	Five LED's (LED's 1-5 from left to right)
8	Power cable	9	Signal cable (PWM)
	<p>1x230V -15% +10% 50/60 Hz</p> <p>If an external relay is used, check if it can stand the inrush current.</p>		<p>Connecting signal cables to incorrect poles can damage the pump.</p> <p>If the signal connection is not needed, it can be covered by a blind plug.</p>

UPM3 Fault Indication:

- There are five LEDs on the UPM3. If the pump detects one or more alarms, LED 1 switches from green to red and one of the other LEDs lights yellow.
- If multiple alarms are active at the same time, the LEDs only show the error of the highest priority. The priority is defined by the sequence of the table as shown in the table below.
- When there is no active alarm anymore, the operating panel switches back to operating mode.

LED					Indication	Pump operation	Counter action
1	2	3	4	5			
☑				☑	Rotor is blocked	Trying to start again every 1.33 seconds	Wait or deblock the shaft using a screwdriver
☑			☑		Supply voltage too low	Only warning. Pump runs	Control the supply voltage
☑		☑			Electrical error	Pump is stopped	Control the supply voltage. Replace the pump

Specific for the Grundfos UPM4:

Operating panel		Key	
		1	QR code for quick guide
		2	Error indicator
		3	External communicator indicator
		4	Area for customer specific logo
		5	Grundfos data matrix
		6	Grundfos logo
		7	Grundfos pump type
		8	Customer product number or barcode
9	Power cable	10	Signal cable (PWM)
		1x230V -15% +10% 50/60 Hz If an external relay is used, check if it can stand the inrush current.	
		Connecting signal cables to incorrect poles can damage the pump. If the signal connection is not needed, it can be covered by a blind plug.	

UPM4 Fault Indication:

- There is a single LED on the UPM4 used to indicate an alarm ("Error Indicator"):

Alarm LED is red	Indication	Pump operation	Counter action
	The rotor is blocked	Trying to start again every 1.33 seconds	Wait or deblock the shaft using a screwdriver
	Electrical error	Pump is stopped	Control the supply voltage. Replace the pump

UPM3 Terminal box		UPM4 Terminal box	
1	Input power at minimum and maximum performance	18	Related current at minimum and maximum performance
2	Product mark (legal product code)	17	Input power at minimum and maximum performance
3	Average power input $P_{L,avg}$ (Ecodesign regulation)	16	Maximum operating pressure
4	Temperature class	15	Average power input $P_{L,avg}$ (Ecodesign regulation)
5	Minimum liquid temperature (only cold-water pumps)	14	Temperature class
6	Production code (year and week) and customer ID	13	Minimum liquid temperature (only cold-water pumps)
7	Enclosure class	12	Production code (year and week) and customer ID
8	Production site	11	Enclosure class
9	Serial number	10	Production site
10	Product number	9	Serial number
11	Frequency [Hz]	8	Product number
12	Voltage [V]	7	Frequency [Hz]
13	Energy index with indication of measurement standard	6	Voltage [V]
14	CE mark and approvals	5	Energy index with indication of measurement standard
15	Maximum	4	CE mark and approvals
16	Minimum	3	Maximum
17		2	Minimum
18		1	

Pump curves:

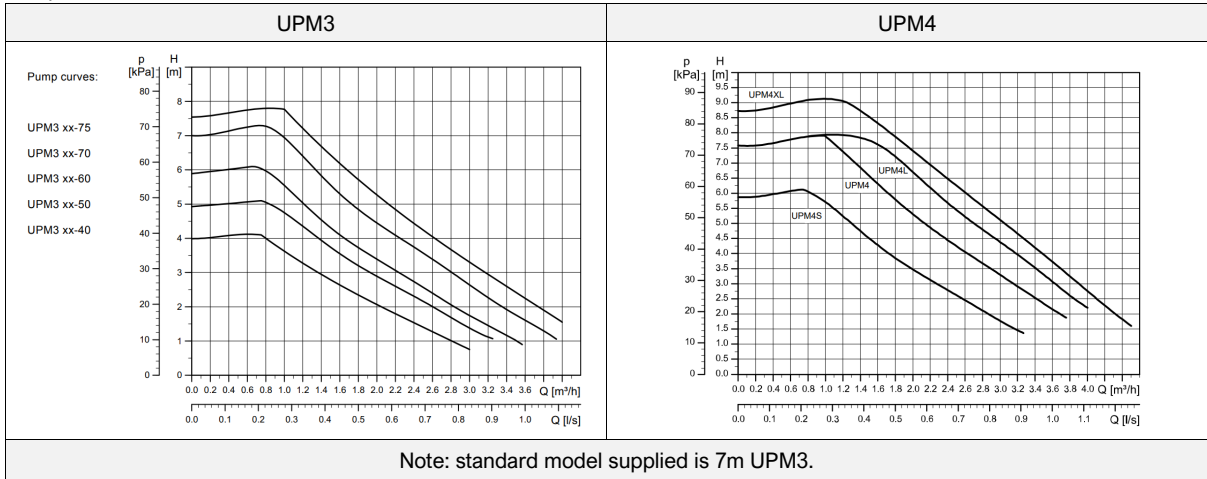

7.3 Wilo Pump curves and technical

<p>Technical details have been summarised in the pages below. For full details visit manufacturers website, or click/scan the QR code adjacent:</p>	
---	--

The Wilo SC (Self Control) pumps have three control modes; variable differential pressure ($\Delta p-v$), constant differential pressure ($\Delta p-c$) and constant speed.

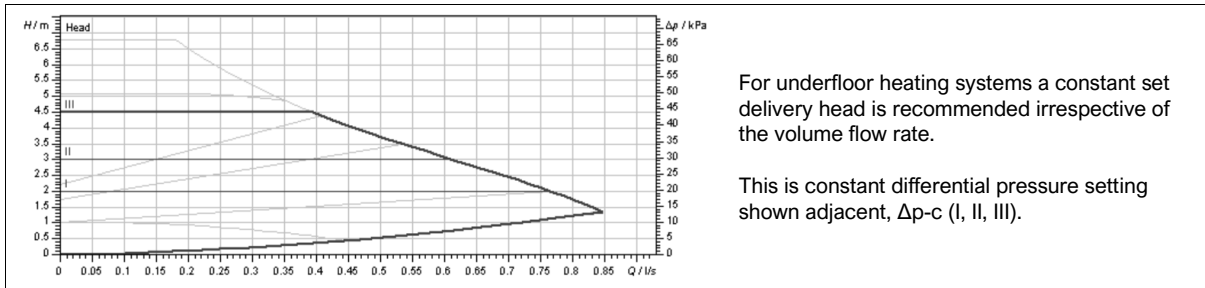

These products are suitable for the following:

- Heating water according to German standard VDI 2035.
- Water-glycol mixtures with a maximum of 50% glycol.

1	Pump housing with screwed connections
2	Glandless motor
3	Condensate drain openings (4x around circumference)
4	Housing screws
5	Control module
6	Rating plate
7	Operating button for pump adjustment
8	Run signal / fault signal LED
9*	Display of selected control module
10	Display of selected characteristic curve (I, II, III)

*(9)		<p>First row of LEDs indicates selected control mode: Variable dP, constant dP and constant speed.</p> <p>Second row of LEDs indicates the pump curve: I, II or III.</p>
------	--	--

Button functions:

- Short press (< 1 sec): switch between different hydraulic curves.
- Long press (3 secs, top/bottom LEDs flash every second for 10mins): air vent on.
- Long press (4 secs while switching off the pump; all LEDs flash for 1 second): factory setting.
- Long press (8 secs, LEDs for setting selected flash briefly): special function key lock on or off.

Fault signals:

LED	Indication	Pump operation	Counter action
Lights up red	Blocking	Rotor blocked	Activate manual restart or contact customer service
	Contacting / winding	Winding defective	
Flashes red	Under / over voltage	Power supply too low / high on mains side	Check mains voltage and operating conditions, and request customer service
	Excessive module temperature	Module interior too warm	
	Short circuit	Motor current too high	
Flashes red / green	Generator operation	Water is flowing through the pump hydraulics, but there is no mains voltage at the pump	Check the mains voltage, water quantity / pressure and the ambient conditions
	Dry run	Air in the pump	
	Overload	Sluggish motor, pump is operated outside of its specifications (e.g. high module temperature). The speed is lower than during normal operation	

7.4 Stuart Turner Pump curves and technical

Technical details have been summarised in the pages below. For full details visit manufacturers website, or click/scan the QR code adjacent:



The Stuart Turner pump capacity can be changed to 4m or 6m in service mode. To activate the service mode, the pump must be off for at least 15 seconds, before turning on and then holding both buttons together within 3 seconds. After this period, the capacity can be changed using the mode button. Once selected, the pump must again be power cycled off/on for setting to take effect.

To vent the pump, set the pump to level III and let it run for at least 20 minutes. Once this period has ended, the pump setting must be changed back manually to the required setting.

	1	Operating mode display: Displays current operating mode.
	2	Energy consumption: Displayed in watts.
	3	Auto Smartadapt mode display: Displays status of mode. The factory default is set to Auto Smartadapt.
	4	Automatic night reduction mode display: Displays status of mode.
	5	Automatic night reduction mode button: This button sets night reduction mode. Switched only if the flow temperature drops by over 10 – 15 °C in 1hr. When this rises by 3 °C the pump will then switch back.
	6	Operating mode button: This button sets the mode of operation. There are a total of 9 operating modes in total.

Minimum inlet pressure:

Liquid temperature	< 75°C	75 - 95°C	90 - 110°C
Pressure	0.005 MPa 0.05 bar	0.03 MPa 0.3 bar	0.11 MPa 1.1 bar

Error codes:

Pump error code	Cause	Counter action
E1	Rotor block	Isolate pump electrically and hydraulically. Allow the unit to cool, before draining water content. Loosen the four pump head screws and remove the head. Turn the rotor manually and remove any system debris before reassembling. If the issue persists, replace the pump.
E2	Electronics malfunctions	Isolate pump electrically for at least 1 minute.
E3	Over and under voltage	If the issue persists, replace the pump.
E4	Electronics malfunction, short circuit	Replace the pump

Pump curve:

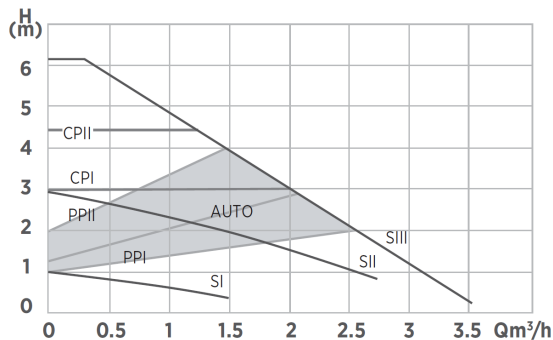

7.5 Wita Pump curves and technical

Technical details have been summarised in the pages below. For full details visit manufacturers website, or click/scan the QR code adjacent:



Control panel & LED display:

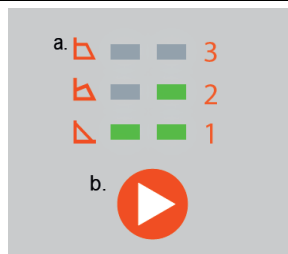

- a) Display of current characteristic curve or fault code
b) Operating mode button

Operating mode button functions:

- Short press (< 1 sec): switch between different hydraulic curves.
- Long press (all LEDs flash 2 or 3 times): special function night mode.
- Long press (all LEDs flash 4 or 5 times): special function automatic air vent on.
- Long press (all LEDs flash 6 or 7 times): special function key lock on or off.

Minimum inlet pressure:

Liquid temperature	< 75°C	75 - 95°C	90 - 110°C
Pressure	0.005 MPa 0.05 bar	0.03 MPa 0.3 bar	0.11 MPa 1.1 bar

Fault signals:

Signal	Cause	Counter action
The pump does not deliver, the display does not light up	Error in the power supply	Check the mains voltage at the pump. If necessary, switch on the circuit breaker again.
The pump works but delivers no water	Air in the system	Vent the system
	Slide valve closed	Open the slide valve
The pump is making noise	Air in the pump	Vent the system
	System pressure is too low	Increase the pressure on the supply
	Defective expansion vessel	Check gas volume in the expansion vessel
Building does not get warm	Incorrect pump setting	Increase the setpoint
	Rotor blocked	Isolate pump electrically and hydraulically. Allow the unit to cool, before draining water content. Loosen the four pump head screws and remove the head. Turn the rotor manually and remove any system debris before reassembling. If the issue persists, replace the pump.
	Electronic fault	Isolate pump electrically for at least 1 minute. If the issue persists, replace the pump.
	Overvoltage or undervoltage	
	Over current, short circuit	Replace the pump
	Dry run protection	Increase the pressure on the supply

Pump curves:

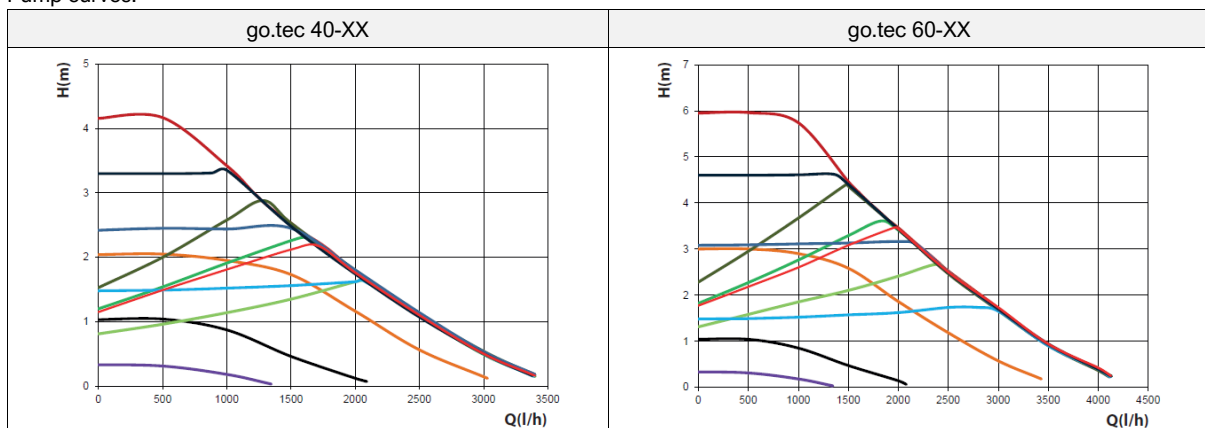

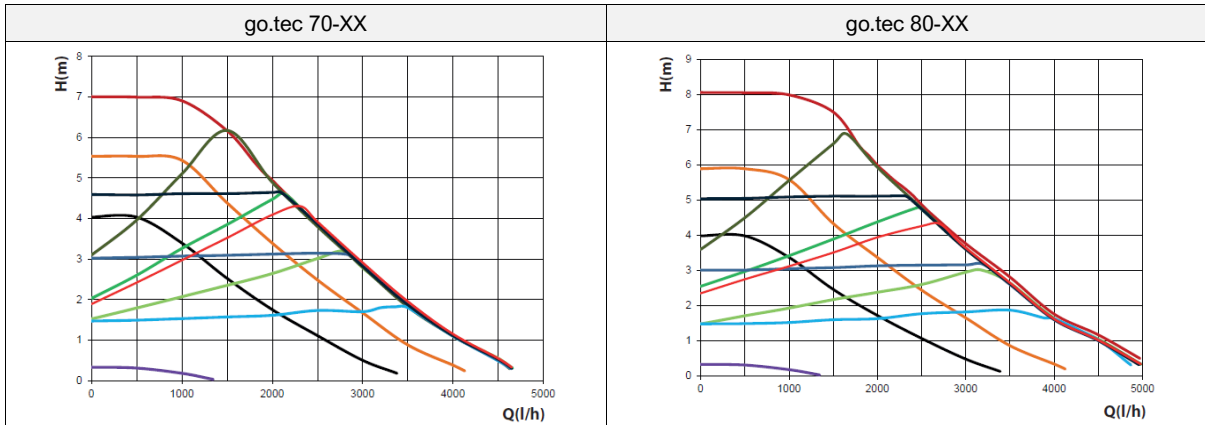

7.6 Replacing the pump

Before dismantling or removing the pump, isolate the product and allow to cool before draining the water content. Note arrows on the pump housing indicate the liquid flow direction through the pump. This arrow must always face the direction of flow rate.

Check the gaskets and consider replacing whenever a new pump is fitted. Tighten the pump flange nuts maximum 30 Nm after replacement.

It must be possible to vent the system at the highest part of each system segment, to remove any air introduced during replacement. Once installation is complete, the pump should run for a period not less than 2 hours to vent the system. It is also recommended that the pump runs for a period every day.

	<p>Warning: Strong magnetic field in the rotor area of the pump, danger of death for persons with pacemaker.</p> <ul style="list-style-type: none"> • Please keep a safe distance of at least 0.3m during disassembly.
--	--

7.7 Replacing the internal mixing components

In the rare event that the internal components of the mixing valve are damaged and require replacement, a spares pack “VTA937” is available (article number 37001700). In this pack are the four components indicated with an asterisk (*):

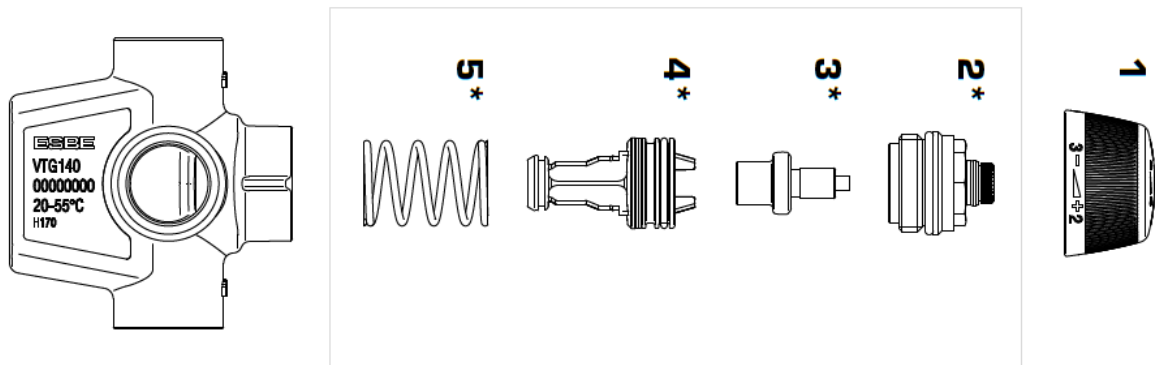

To replace these components, we recommend isolating the control pack electrically and hydraulically, and draining any water content from the valve prior to removing/refitting the cartridge components.

7.8 Fault finding

Fault	Cause	Solution
Mixed temperature much lower than mixing valve setpoint	The flow rate is too low Mixing valve faulty	Increase flow rate (min. 9 l/m required). Replace the mixing valve
Noise in the pump	There is air in the pump	Run the pump, it will self-vent over time
	Inlet pressure too low	Increase system pressure or check air volume in expansion tank if present
Noise in the system	There is air in the system	Vent the system
	Differential pressure too high	Reduce pump performance at pump
Pump is not running, no power supply	System is switched off	Check the controller
	A fuse has blown	Replace the fuse, check for short circuit
	Power supply failure	Check the power supply
Pump is not running, normal power supply	Controller is switched off	Check controller is on / review settings
	Pump is blocked by system debris	Deblock the pump by inserting screwdriver in front of pump. Check and remove debris
	Pump is faulty	Replace the pump
Insufficient flow rate	Pump setting set too low	Check pump settings / external controller if present
	Hydraulic system is closed or there is insufficient system pressure	Check non-return valves and filters. Increase system pressure if needed
Pump runs at maximum speed and is not controlled	No signal from signal cable	Check if signal cable is fitted. If it is replace the cable

7.9 Product guarantee

This product has a non-transferable 2-year guarantee from the date of delivery. This covers faulty product or workmanship to the terms and conditions that can be found on our website.

This O&M has been designed to provide recommendations throughout, which if carried out will help to prolong product lifespan and provide better functionality and accuracy.

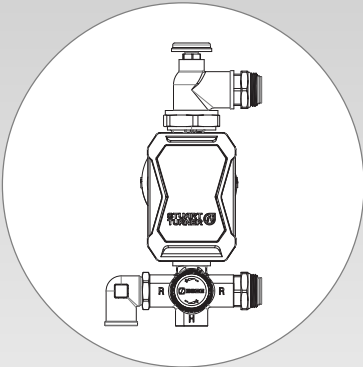
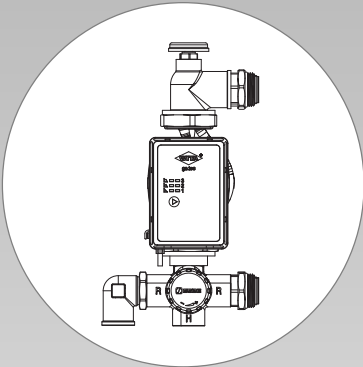
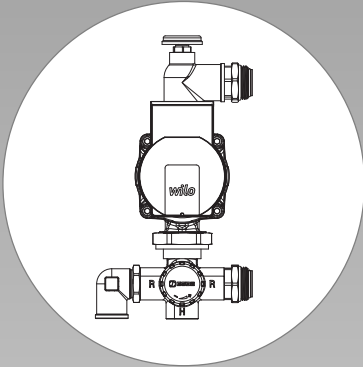
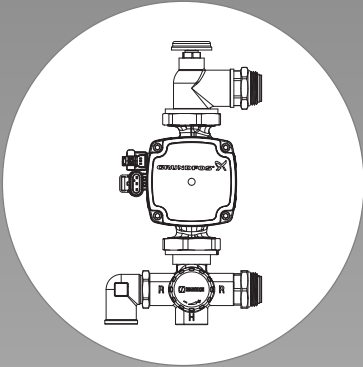

Disclaimer

While every effort has been made to ensure that the information contained in this publication is accurate at the time of publishing, Essco Group assume no responsibility or liability for typographical errors, omissions or any misinterpretation of the information provided. Essco Group also reserve the right to update, or change said publication without notice.